

INSTALLER AND OWNER GUIDE

AIRFLAME

MODEL	PRODUCT CODE
AF 16 NV	9500298 (coal) 0505411 (log)
AC 16 NV	9500296 (coal) 0505511 (log) 0503611 (pebble)
AF 18 XL	9500360 (coal)
AC 18 XL	9500361 (coal)

MODEL	PRODUCT CODE
AF 16 NV 5" Leg	9505298 (coal)

MODEL	PRODUCT CODE
AF 16 NV RC	0505601 (coal) 0505611 (log)
AC 16 NV RC	0505701 (coal) 0505711 (log)
AF 18 XL RC	0505301 (coal)
AC 18 XL RC	0505901 (coal)

MODEL	PRODUCT CODE
AC 16 NV TC	05036T1 (coal) 0505811 (log)



We trust that this guide gives sufficient details to enable this appliance to be installed, operated and maintained satisfactorily. However, if further information is required, our **Wonderfire Technical Helpline** will be pleased to help. Telephone **0844 8711 565**. (National call rates apply in the United Kingdom). In the Republic of Ireland Telephone **0044 844 8711 565**.



INSTALLER: Please leave this guide with the owner

INSTALLER GUIDE

**THIS APPLIANCE IS FOR USE WITH NATURAL GAS (G20).
WHEN CONVERTED USING CONVERSION KITS AS SHOWN IN SECTION 2 OF
THE INSTALLER GUIDE THE SPECIFIED APPLIANCES ARE FOR USE WITH
PROPANE GAS (G31).**

**THIS APPLIANCE IS SUITABLE ONLY FOR INSTALLATION IN THE UNITED
KINGDOM (GB) AND THE REPUBLIC OF IRELAND (IE).**

© Baxi Heating U.K. Limited 2008.

All rights reserved. No part of this publication may be reproduced in any material form (including photocopying), stored in any medium by electronic means (including in any retrieval system or database) or transmitted, in any form or by any means, whether electronic, mechanical, recording or otherwise, without the prior written permission of the copyright owner.

Applications for the copyright owner's permission to reproduce any part of this publication should be made, giving details of the proposed use, to the following address: The Company Secretary, Baxi Heating UK Limited, The Wyvern Business Park, Stanier Way, Derby, DE21 6BF.

Warning: Any person who does any unauthorised act in relation to a copyright work may be liable to criminal prosecution and civil claims for damages.



Wonderfire, Wood Lane, Erdington, Birmingham B24 9QP
www.wonderfire.co.uk

Because our policy is one of constant development and improvement, details may vary slightly from those given in this publication

INSTALLER GUIDE

Safety First.

Wonderfire fires are CE Approved and designed to meet the appropriate British Standards.



The Highest Standards

Wonderfire is a member of SBGI and HHIC (Heating and Hot water Industry Council) which works to ensure high standards of safety, quality and performance.



Careful Installation

Wonderfire is a CORGI registered company. All our gas fires must be installed by a competent CORGI Registered Installer in accordance with our Installer Guide.



INSTALLER GUIDE

FOR OWNER GUIDE SEE PAGES 38 TO 55

INSTALLER GUIDE

CONTENTS

<u>Section</u>	<u>Page</u>
INSTALLER GUIDE	4 - 37
OWNER GUIDE	38 - 55
1. SAFETY	6
2. LPG CONVERSION	6
3. APPLIANCE DATA	7
4. GENERAL INSTALLATION REQUIREMENTS	9
5. UNPACKING THE APPLIANCE	15
6. INSTALLATION OF STANDARD AND LARGE CONVECTION BOXES.	16
7. BURNER AND SUPPLY PIPE INSTALLATION	23
8. FITTING THE CERAMIC FUEL EFFECT	24
9. FULL OPERATIONAL CHECKS	24
9.1 General information.	24
9.2 Checking the operation of the MANUAL CONTROL burner.	24
9.3 Checking the operation of the REMOTE CONTROL (RC)burner.	25
9.4 Adjusting the remote control handset / receiver code.	27
9.5 Checking the operation of the TOP CONTROL (TC) burner.	27
9.6 Inlet pressure check.	29
9.7. Aeration setting for fires fitted with aeration control.	30
10. SPILLAGE AND FLAME SUPERVISION CHECKS	30
11. DECORATIVE FIREFRONTS	33
12. FINAL REVIEW	34
13. SERVICING & PARTS REPLACEMENT	35
13.1 Annual maintenance.	35
13.2 To remove the injector.	36
13.3 To remove the thermocouple & pilot unit.	36
13.4 To remove the gas valve unit.	36
13.5 To remove the convection box from the fireplace (For models fitted into a convection box).	37

INSTALLER GUIDE

1. SAFETY

Installer: Before continuing any further with the installation of this appliance please read the following guide to manual handling.

- The approximate lifting weight of this appliance is as below:

<u>Model</u>	<u>Heat Engine (kg)</u>	<u>Convection box (kg)</u>
AF 16 NV	1.8	Not supplied
AC 16 NV	1.8	9.45
AF 18 XL	2.0	Not supplied
AC 18 XL	2.0	18.7
AF 16 NV RC	3.4	Not supplied
AC 16 NV RC	3.4	9.45
AF 18 XL RC	2.0	Not supplied
AC 18 XL RC	2.0	18.7
AF 16 NV 5" Leg	2.0	Not supplied
AC 16 NV TC	3.0	11.33

- One person should be sufficient to lift the fire. If for any reason this weight is considered too heavy then obtain assistance.
- When lifting always keep your back straight. Bend your legs and not your back.
- Avoid twisting at the waist. It is better to reposition your feet.
- Avoid upper body/top heavy bending. Do not lean forward or sideways whilst handling the fire.
- Always grip with the palm of the hand. Do not use the tips of fingers for support.
- Always keep the fire as close to the body as possible. This will minimise the cantilever action.
- Use gloves to provide additional grip.
- Always use assistance if required.

2. LPG CONVERSION

The following conversion kits are available to convert from natural gas (G20) to propane gas (G31).

MODEL	CONVERSION KIT PART NUMBER
AF16NVP / AC16NVP* / AC16NVPTC	9500365
AF16NVP RC / AC16NVP RC	9500376
AF18XLP / AC18XLP	9500362
AF18XLP RC / AC18XLP RC	9500377

*** Important: The AC16NV Model supplied / fitted with a ceramic PEBBLE fuel effect shall not be converted to LPG.**

INSTALLER GUIDE

3. APPLIANCE DATA

The efficiency of this appliance has been measured as specified in BS 7977 - 1 and the result is as below:

<u>Model</u>	<u>Efficiency %(Gross)</u>	<u>Model</u>	<u>Efficiency %(Gross)</u>
AC 16 NV RC	53	AC 16 NV	53
AC 18 XL RC	55	AC 18 XL	55
AC 16 NV TC	53		

AF models are not included above as they have a default value included in the SAP calculation.

The gross calorific value of the fuel has been used for this efficiency calculation. The test data from which it has been calculated has been certified by Advantica Certification services (0087). The efficiency value may be used in the UK Government's Standard Assessment Procedure (SAP) for energy rating of dwellings.

The conversion of **net** efficiency to **gross** was achieved by multiplying the net efficiency by the following conversion factor from Table E3 of SAP 2005, rounding down to the nearest whole number.

Gas	Conversion factor from net to gross efficiency
Natural Gas	0.901
LPG	0.921

This product uses fuel effect pieces and burner (AC models also include a burner compartment rear wall) containing Refractory Ceramic Fibres (RCF), which are man-made vitreous silicate fibres. Excessive exposure to these materials may cause irritation to eyes, skin and respiratory tract. Consequently, it is important to take care when handling these articles to ensure that the release of dust is kept to a minimum. To ensure that the release of fibres from these RCF articles is kept to a minimum, during installation and servicing we recommend that you use a HEPA filtered vacuum to remove any dust and soot accumulated in and around the fire before and after working on the fire. When replacing these articles we recommend that the replaced items are not broken up, but are sealed within a heavy duty polythene bag, clearly labelled as RCF waste. RCF waste is classed as a stable, non-reactive hazardous waste and may be disposed at a landfill licensed to accept such waste. Protective clothing is not required when handling these articles, but we recommend you follow the normal hygiene rules of not smoking, eating or drinking in the work area and always wash your hands before eating or drinking. This appliance does not contain any component manufactured from asbestos or asbestos related products.

INSTALLER GUIDE

MODEL	GROSS HEAT INPUT (kW)		INLET PRESSURE (TO BE TAKEN ON MAX. SETTING WITH THE FIRE COLD).	INJECTOR SIZE
	MIN.	MAX.		
AF16NV (Coal or Log) AC16NV (Coal or Log) AC16NV TC (Coal or Log) AF16NV 5" LEG (Coal)	4.8	6.95	20.0mbar ± 1.0mbar (8.0 ± 0.4in w.g.)	82 - 442
AF16NV RC (Coal or Log) AC16NV RC (Coal or Log)	3.2	6.95	20.0mbar ± 1.0mbar (8.0 ± 0.4in w.g.)	82 - 442
AC16NV (Pebble)	4.8	6.3	20.0mbar ± 1.0mbar (8.0 ± 0.4in w.g.)	82 - 069
AF16NVP AC16NVP	5.8	6.2	37.0 ± 1.0 mbar (14.85 ± 0.4in w.g.)	92 - 200
AF16NVP RC AC16NVP RC	4.3	6.2	37.0 ± 1.0 mbar (14.85 ± 0.4in w.g.)	92 - 200
AF18XL AC18XL	5.8	10.5	20.0mbar ± 1.0mbar (8.0 ± 0.4in w.g.)	82 - 722
AF18XL RC AC18XL RC	5.8	10.5	20.0mbar ± 1.0mbar (8.0 ± 0.4in w.g.)	82 - 722
AF18XLP AC18XLP	7.6	9.0	37.0 ± 1.0 mbar (14.85 ± 0.4in w.g.)	92 - 260
AF18XLP RC AC18XLP RC	7.6	9.0	37.0 ± 1.0 mbar (14.85 ± 0.4in w.g.)	92 - 260

INSTALLER GUIDE

MODEL	BURNER TRAY DIMENSIONS		
	WIDTH	DEPTH	HEIGHT (INCLUDING FUEL EFFECT)
AF16NV AC16NV AF16NV RC AC16NV RC AF16NV TC	380mm (15") at front tapering to 280mm (11") at the rear	225mm (9")	305mm (12")
AF16NVP AC16NVP AF16NVP RC AC16NVP RC			
AF16NV 5" LEG	As Above	As Above	345mm (13½")
AF18XL AC18XL AF18XL RC AC18XL RC	430mm (17") at the front tapering to 300mm (11¾") at the rear	225mm (9")	305mm (12")
AF18XLP AC18XLP AF18XLP RC AC18XLP RC			

4. GENERAL INSTALLATION REQUIREMENTS

4.1 The installation must be in accordance with these instructions.

For the user's protection, in the United Kingdom it is the law that all gas appliances are installed by competent persons in accordance with the current edition of the Gas Safety (Installation and Use) Regulations. Failure to install the appliance correctly could lead to prosecution. CORGI requires its members to work to recognised standards.

In the United Kingdom the installation must also be in accordance with:

All the relevant parts of local regulations.

All relevant codes of practice.

The relevant parts of the current editions of the following British Standards:-

BS 1251 (Fireplace Components)

BS EN 1856 Part 1

BS 5440 Part 1

BS 5440 Part 2

BS 5871 Part 2

BS 5871 Part 3

BS 6461 Part 1

BS 6891 (Masonry chimney & flues - Installation)

BS 8303

In England and Wales, the current edition of the Building Regulations issued by the Department of the Environment and the Welsh Office. In Scotland the current edition

INSTALLER GUIDE

of the Building Standards (Scotland) Regulations issued by the Scottish Executive. In Northern Ireland, the current edition of the Building Regulations (Northern Ireland) issued by the Department of the Environment for Northern Ireland. In the Republic of Ireland the installation must also conform with the relevant parts of:

The current editions of:-

IS 813 "Domestic Gas Installations"

ICP3

IS327

All relevant national and local rules in force.

Where no specific instructions are given, reference should be made to the relevant British Standard Code of Practice.

4.2 Improper installation of this gas fire could be hazardous to health. This gas fire is to be used only in a properly flued, incombustible, masonry fireplace with the chimney or flue free from obstruction.

4.3 As supplied the appliance can be installed in the following situations: -

To a fireplace complete with a hearth complying with BS1251. The required hearth and clearance dimensions are shown in figure 1. (Remove any existing heating appliance - when using a convection box it may be necessary to remove the firebrick back). When installing using a convection box see section 6.

Suitable flues and minimum flue sizes are as follows: -

a) 225mm x 225mm conventional brick flue.

b) 175mm diameter lined brick or stone flue.

c) 200mm diameter factory made insulated flue manufactured to BS EN 1856 Part 1

d) 175mm diameter flue pipe. See BS6461 Part 1 for suitable materials.

Additional flue information for NV models fitted to convection boxes.

In addition to the flues specified in section 4.3 **NV MODELS** can be used on the following flue:

A correctly installed metal flue with a minimum diameter of 125mm (5") is acceptable for NV models only, providing both **inner** and **outer** convection box restrictor plates are removed (See section 6.6 - point 3).

Larger fireplace openings may require a correspondingly larger chimney diameter, a faulty flue or chimney may result in products of combustion spilling into the room with consequent possible damage to furniture and decor. Conduct a smoke test before proceeding with installation. Refer to the section 6.4.5 "Fireplace flue pull".

The minimum effective height of the flue must be 3m.

The flue must not be used for any other appliance or application.

Any chimney damper or restrictor should be removed. If removal is not possible, they must be secured in the open position.

If the appliance is intended to be installed to a chimney that was previously used for

INSTALLER GUIDE

solid fuel, the flue must be swept clean prior to installation.
All flues should be inspected for soundness and freedom from blockages.

For Essence models only

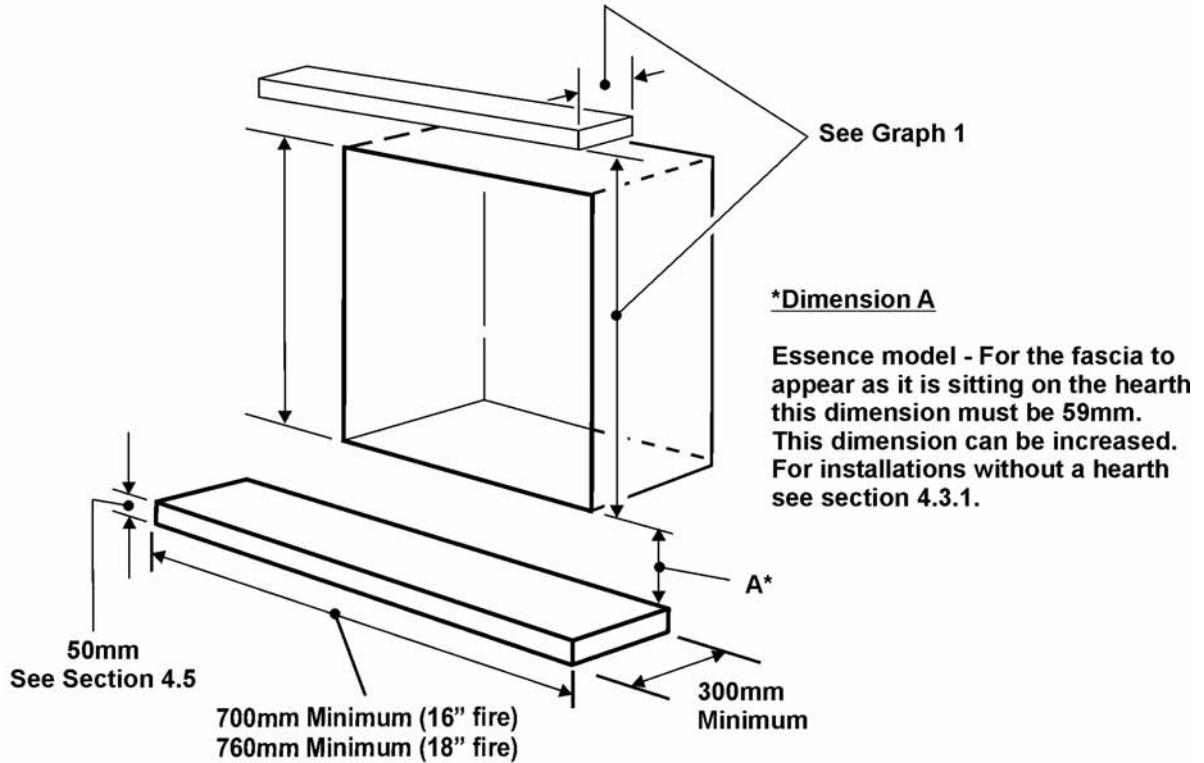

For all other models

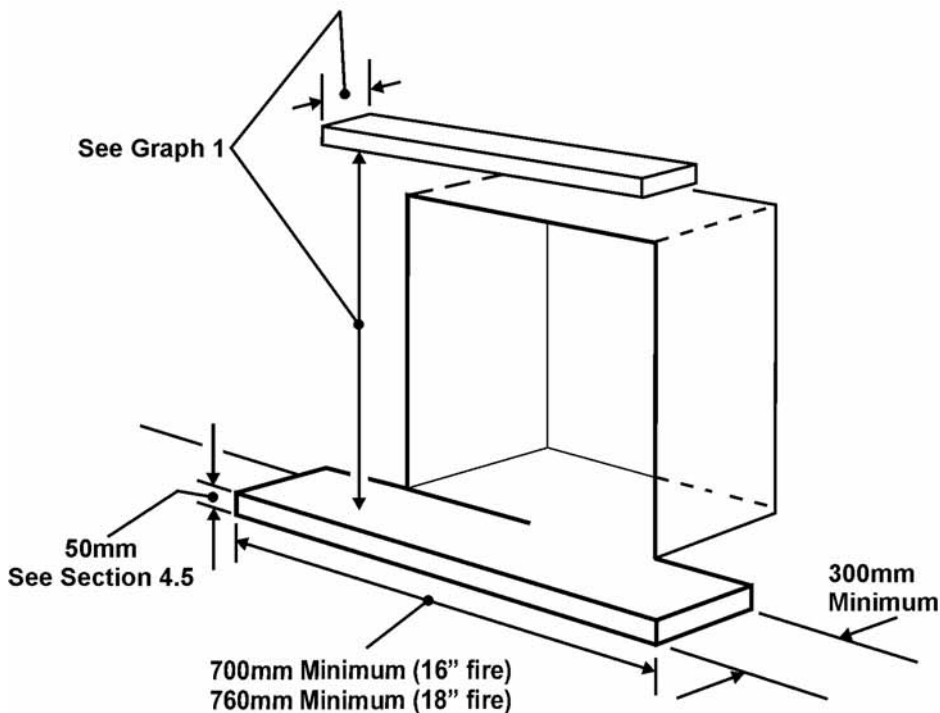

Figure 1. Hearth sizes.

INSTALLER GUIDE

4.3.1. 'Hole-in-the-wall' / elevated installations -

- It is recommended that a hearth should be installed as in section 4.5.

For models fitted with the Essence fascia - The fascia has been specifically designed for 'hole in the wall' installations. It is recommended that a hearth should be installed as in figure 1. If a hearth is not fitted, the fire must be installed so that the distance from the base of the fireplace opening in the wall to the finished floor level is at least 115mm (This will give a distance under the fascia of 56mm to the finished floor level). Where there is no floor covering or carpet and the floor is of a type that is likely to be covered in such a way then the distance from the base of the fireplace opening in the wall to the finished floor level should be increased to at least 190mm.

For models NOT fitted with 5" legs (excluding the Essence model) - If a reduced depth hearth is fitted, the fire must be installed so that the distance from the base of the fireplace opening in the wall to the finished floor level is 115mm minimum. Where there is no floor covering or carpet and the floor is of a type that is likely to be covered in such a way in the future then the distance from the base of the fireplace opening in the wall to the floor level should be increased to at least 190mm.

- It is recommended that the reduced hearth has a depth from the fixing plane of the fire of 100mm minimum. This is necessary to support the lower front casting / firefront.

For models fitted with 5" legs - If a reduced depth hearth is fitted, the fire must be installed so that the distance from the base of the fireplace opening in the wall to the finished floor level is 75mm minimum. Where there is no floor covering or carpet and the floor is of a type that is likely to be covered in such a way in the future then the distance from the base of the fireplace opening in the wall to the floor level should be increased to at least 150mm.

- It is recommended that the reduced hearth has a depth from the fixing plane of the fire of 100mm minimum. This is necessary to support the lower front casting / firefront.

All models

- To protect from the risk of burns and ignition of clothing a tactile separator shall be used. The hearth detailed in section 4.5 meets the requirements for a tactile separator.

For 16" fires - If this is not used then a 700mm long fender, kerb, horizontal bar, or other barrier, being fixed not less than 50mm above floor level and positioned 300mm in front of the fixing plane of the fire will meet the requirement.

For 18" fires - If this is not used then a 760mm long fender, kerb, horizontal bar, or other barrier, being fixed not less than 50mm above floor level and positioned 300mm in front of the fixing plane of the fire will meet the requirement.

INSTALLER GUIDE

4.4 If the fireplace opening is an underfloor draught type, it must be sealed to stop any draughts.

4.5 The appliance must be mounted behind a non-combustible hearth unless the conditions of section 4.3.1 are met (N.B. conglomerate marble hearths are considered as non-combustible). The appliance can be fitted to a minimum class “O” – 150°C surround. The hearth material must be at least 12mm thick. The periphery of the hearth (or fender) should be at least 50mm above floor level to discourage the placing of carpets or rugs over it (See figure 1). On none elevated installations the surface of the hearth must be sufficiently flat to enable the bottom of the fascia and the bottom front cover to be aligned horizontally. Any excessive unevenness (uneven tiles, Cotswold stone, etc.) should be rectified. The base of the fireplace opening must be level with the top surface of the hearth. There should be no gaps between the hearth and the fireplace opening.

4.6 The minimum height from the base of the fireplace opening to the underside of any shelf made from wood or other combustible materials is as follows: -

- For a shelf up to 150mm deep

Minimum height = 818mm.

- For a shelf deeper than 150mm

818mm + 12.5mm for every 25mm depth over 150mm

(See Graph 1).

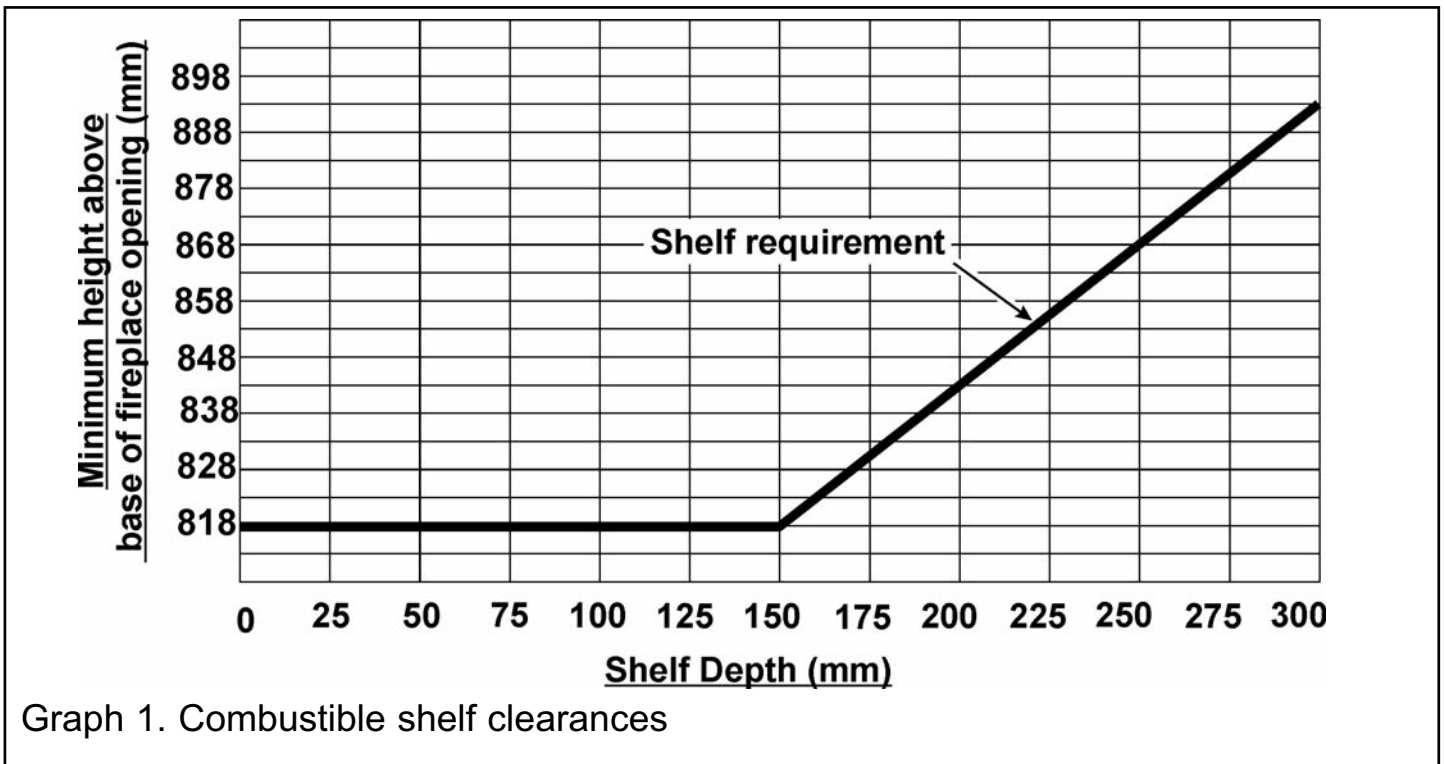

Graph 1. Combustible shelf clearances

4.7 If the fireplace opening is greater than the opening in the intended surround back, do not use the back of a fire surround or marble to reduce the opening. This may cause cracking of the surround back or marble.

INSTALLER GUIDE

4.8 The appliance must not stand on combustible materials or carpets.

4.9 An extractor fan may only be used in the same room as this appliance, or in any area from which ventilation for the appliance is taken, if it does not affect the safe performance of the appliance. Note the spillage test requirements detailed further on in this manual. If the fan is likely to affect the appliance, the appliance must not be installed unless the fan is permanently disconnected.

4.10 Ventilation.

IE only: This appliance must be installed in accordance with the current edition of IS 813 “Domestic Gas Installations” which makes clear the conditions that must be met to demonstrate that sufficient ventilation is available.

GB only: See the table below for purpose made ventilation requirements. In GB reference should be made to BS 5871 Part 2.

MODEL	HEAT INPUT (kw GROSS)	PURPOSE MADE VENTILATION SIZE (cm ²)
AF16NV / AF16NV RC / AF16NV 5” LEG	6.95 (Coal or Log)	NONE**
AC16NV / AC16NV RC AC16NV TC	6.95 (Coal or Log) / 6.3 (Pebble on AC16NV only)	NONE**
AF18XL / AF18XL RC	10.5	100
AC18XL / AC18XL RC	10.5	15.75
AF16NVP* / AF16NVP RC*	6.2	NONE**
AC16NVP* / AC16NVP RC*	6.2	NONE**
AF18XLP* / AF18XLP RC*	10.5	100
AC18XLP* / AC18XLP RC*	9.0	11.25

* When converted to propane using the kits from section 2 of this guide.

**AF16NV / AF16NVP - see below.

GB only: Normal adventitious ventilation is usually sufficient to satisfy the ventilation requirements of this appliance, however on larger fireplace openings with a height greater than 24” and a width greater than 18” we do recommend that a purpose made ventilation grille with a minimum opening size of 100cm² is fitted. In all cases a clearance of products (spillage test) must be carried out.

IE only: This appliance must be installed in accordance with the current edition of IS 813 “Domestic Gas Installations” which makes clear the conditions that must be met to demonstrate that sufficient ventilation is available. In all cases a clearance of products (spillage test) must be carried out.

4.11 This appliance must not be installed in any room that contains a bath or shower or where steam is regularly present.

INSTALLER GUIDE

4.12 Note that soft wall coverings (e.g. embossed vinyl, etc.) are easily affected by heat. They may scorch or become discoloured when close to a heating appliance. Please bear this in mind when installing.

4.13 A fireguard complying with BS 8423 should be fitted for the protection of young children, the elderly, the infirm or pet animals.

4.14 The appliance is fitted with an A.S.D (Atmosphere sensing device). If the appliance closes down after a period of operation for no apparent reason, the consumer should be informed to stop using the appliance until the installation and appliance have been thoroughly checked. The A.S.D will shut the appliance down if an unacceptable amount of harmful products of combustion accumulate. Under no circumstances should the A.S.D be altered or bypassed in any way. Only a genuine manufacturer's replacement part should be fitted. The individual A.S.D components are not replaceable.

4.15 Propane gas appliances must not be installed in a room that is built entirely below ground level (See BS 5871 Part 3).

Important: The AC16NV Model supplied / fitted with a ceramic PEBBLE fuel effect shall not be converted to LPG.

5. UNPACKING THE APPLIANCE

Carefully remove the contents. Check that all the listed parts are present and in good condition.

Contents:

- 1 Burner assembly.
- 1 Ceramic fuel effect.
- 1 Guarantee card.
- 1 Smoke match tube.

AF MODELS ONLY

- 1 Loose parts pack (1 x fixing screw and fibre wall plug).

AC MODELS ONLY

- 1 Loose parts pack (2 tension wires, 2 cable retainer assemblies and foam seal).
- 1 Convection box.

REMOTE CONTROL (RC) MODELS ONLY

- 1 Remote control handset.
- 1 PP3 battery.
- 4 AA batteries.

(TC) MODELS ONLY

- 4 AA batteries.
- 1 Convection box.

INSTALLER GUIDE

6. INSTALLATION OF STANDARD AND LARGE CONVECTION BOXES.

6.1 General information.

The Standard Wonderfire Convection box is designed to fit into fireplace openings between 16" and 18" and constructed in accordance with the requirements of BS1251. Any chairbrick / fireback will require removal.

The large Wonderfire Convection box is designed to fit into fireplace openings between 19" and 22" and constructed in accordance with the requirements of BS1251. Any chairbrick / fireback will require removal.

There are three grommets supplied with the convection box. The large grommet is to be fitted to the rear hole in the convection box. The two smaller grommets are to be fitted into the holes in the sides of the convection box. The grommets must be fitted before continuing with the installation. On (TC) models the grommet on the right hand side will have to be cut to accommodate the wiring harness.

The installation of any fire other than the listed Wonderfire products will invalidate the approval status and guarantee.

This fireplace insert / Convection box is unsuitable for use with solid fuel.

Note: This appliance is fitted with a restrictor plate. If, after conducting a spillage test (See section 10.1) smoke is not positively drawn into the chimney, this plate must be removed and the spillage test repeated. Also, see section 6.2 below.

If there is a possibility of birds nesting in the area an approved cowl suitable for solid fuel should be fitted.

6.2 Additional flue information for NV models fitted to convection boxes.

In addition to the flues specified in section 4.3 **NV MODELS** can be used on the following flue:

A correctly installed metal flue with a minimum diameter of 125mm (5") is acceptable for NV models only, providing both **inner** and **outer** convection box restrictor plates are removed (See section 6.6 - point 3).

INSTALLER GUIDE

6.3 Convection box sizes.

The convection box sizes are shown in figure 2.

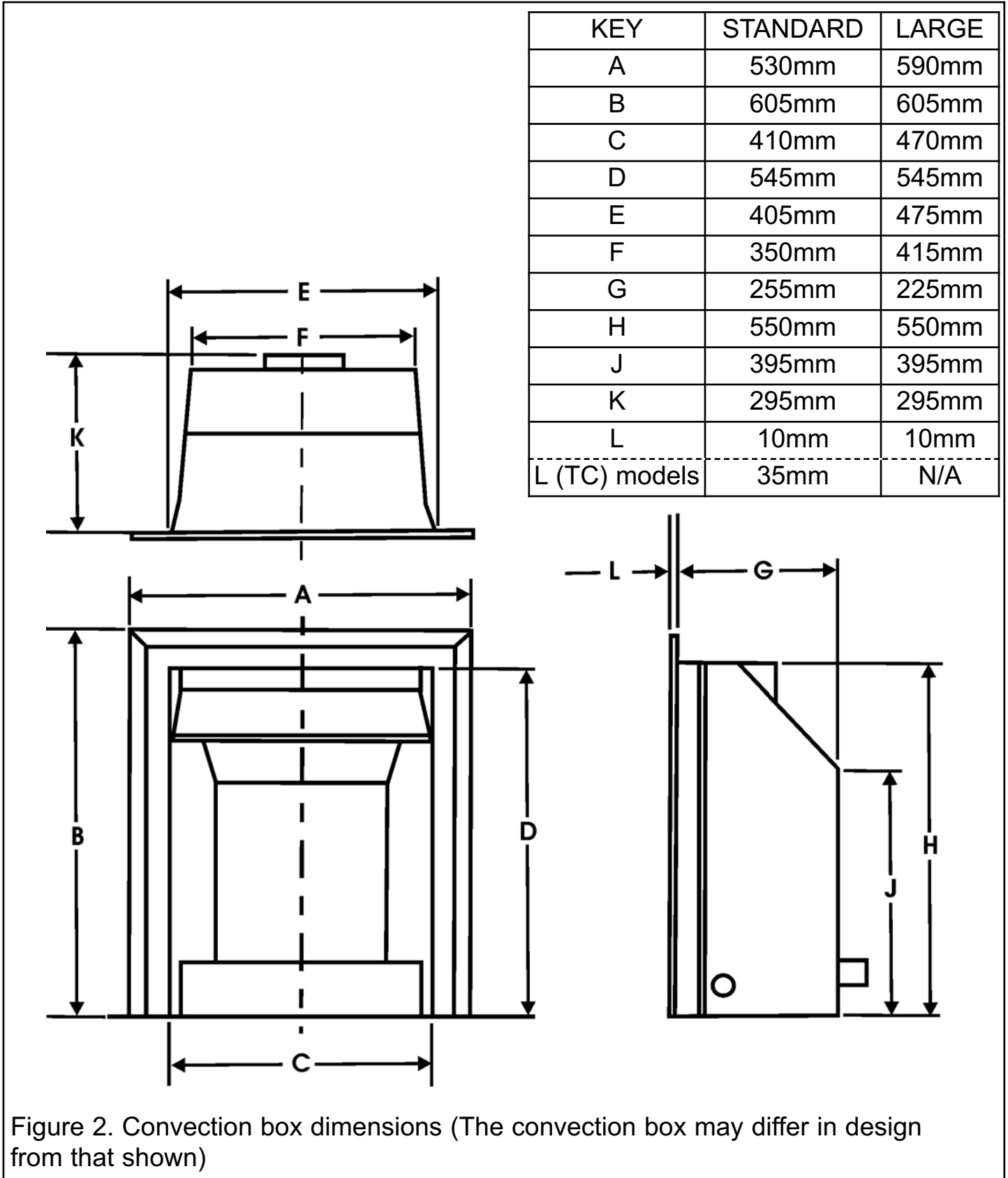

INSTALLER GUIDE

6.4 Fireplace requirements.

6.4.1 Fireplace opening and hearth dimensions.

The fireplace opening should be as shown in figure 3.

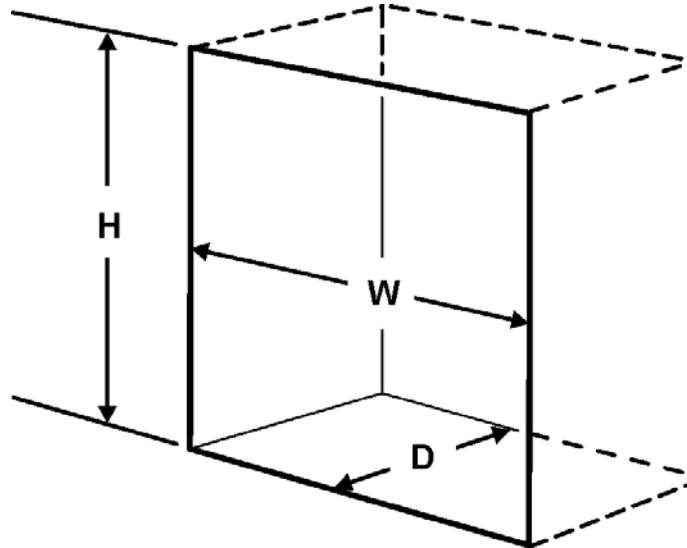

16 inch convector box	Minimum opening sizes	W= 415mm (16½ inch)	H= 560mm (22¼ inch)	D= 305mm (12 inch)
16 inch convector box with (TC)		W= 415mm (16½ inch)	H= 560mm (22¼ inch)	D= 280mm (11 inch)
16 inch convector box & (TC)	Maximum opening sizes	W= 495mm (19½ inch)	H= 585mm (23 inch)	D= NONE
18 inch convector box	Minimum opening sizes	W= 480mm (19 inch)	H= 560mm (22¼ inch)	D= 305mm (12 inch)
18 inch convector box	Maximum opening sizes	W= 560mm (22 inch)	H= 585mm (23 inch)	D= NONE

Figure 3. Hearth and fireplace openings

6.4.2 Fireplace size.

The fireplace must comply with the requirements described in section 4.3. This will probably entail removing the fireback and infill material behind the fireback. The area shown in figure 4 must be kept clear of obstructions.

INSTALLER GUIDE

6.4.3 Fireplace general condition.

The fireplace floor should be reasonably flat to ensure that the convection box can be installed without it rocking and so that a good seal can be made at the bottom front of the box. The front face of the fireplace should be reasonably flat over the area covered by the convection box top and side flange seals to ensure good sealing. These faces should be made good if necessary. If the appliance is to be

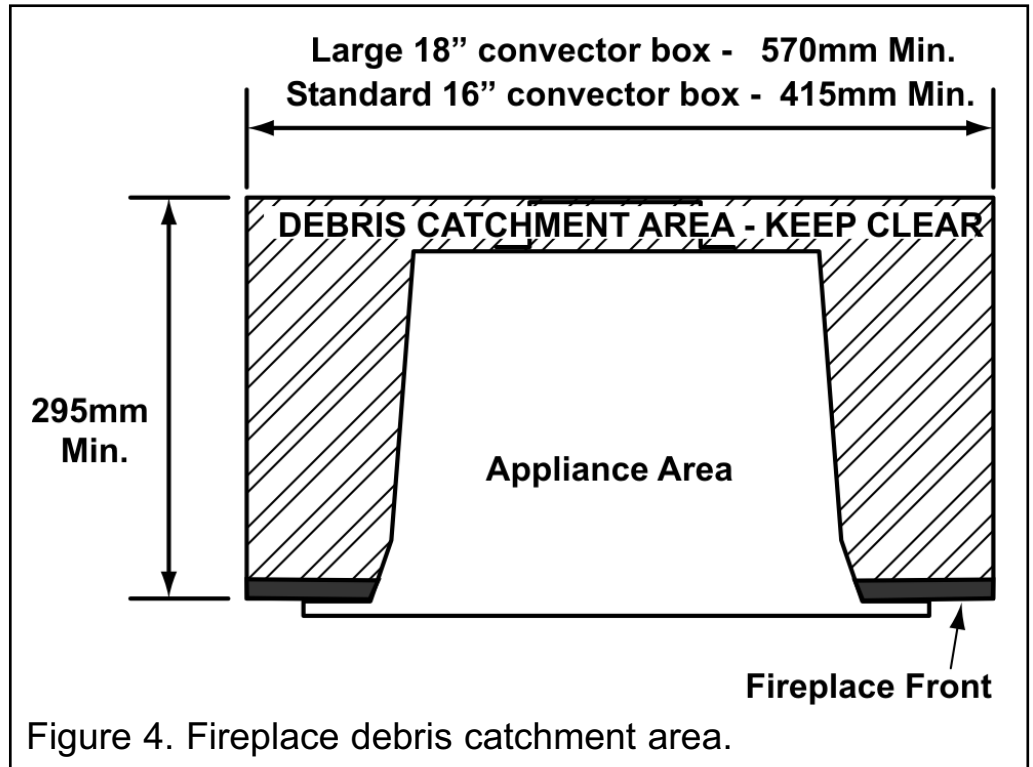

Figure 4. Fireplace debris catchment area.

fitted against a wall with combustible cladding, the cladding must be removed from the area covered by the convection box fascia. The cladding must also not touch the fascia. We suggest that the actual fascia is used as a template to mark the area for combustible cladding removal and that this area is increased by at least 2mm all round.

6.4.4 Soundness for appliance attachment.

The appliance must be secured in place using concealed tension cables fixed to the rear of the fireplace opening (See section 6.7). Make sure that the relevant areas at the fireplace back are sound enough to take the eyebolts. If these areas have deteriorated due to prolonged use they should be made sound with suitable cement.

6.4.5 Fireplace flue pull.

Close all doors and windows in the room in which the appliance is to be installed. After confirming with a match that smoke is drawn into the flue, light a 13 gram smoke pellet and check that there is a definite flow through the flue. Verify outside that the smoke exits from one terminal only and that the termination is suitable. Observe where possible, upstairs rooms and loft spaces for signs of escaping smoke indicating a defective flue. If there is not a definite flow warm the flue for a few minutes and repeat the smoke pellet test. If there is still no definite flow the flue may need remedial work - Do not fit the appliance until there is a definite flow through the flue.

INSTALLER GUIDE

6.5 Gas supply connection.

A nut and olive are provided for an 8mm pipe inlet connection to the 'T' connector at the bottom front of the appliance. The 'T' connector includes a valve for isolating the gas supply and a pressure test point.

The supply pipe must be rigid material. Flexible pipe must not be used.

This appliance is designed for a concealed supply pipe connection routed through the opening at the back or sides of the convection box. Before the appliance is fitted into the fireplace it will be necessary to extend the supply line so that it will project through the grommet in the back / sides of the convection box and run to the 'T' connector at the front. The pipe run from the supply line up to the rear / side opening in the convection box must be kept away from the area which will be taken by the convection box when it is installed (See figure 4).

The inlet 'T' connector should be fitted to the supply pipe at this stage. The access opening at the rear of the convection box is sized to accept the "T" connector.

6.6 Preparing for installation.

1. Detach the burner from the convection box by removing one nut. Lift the burner unit clear.
2. Pierce the appropriate grommet at the back / side of the convection box to allow the supply pipe to pass through it. The grommet should envelop the pipe. If the hole is larger than the pipe, seal it with tape. Do not pierce the grommets unless the supply pipe is to pass through them.
3. **Only for installations having a metal flue of 125mm (See section 6.2)**

Detach the outer restrictor plate by removing four screws (See figure 5).

Detach the inner restrictor plate by removing one screw (See figure 5).

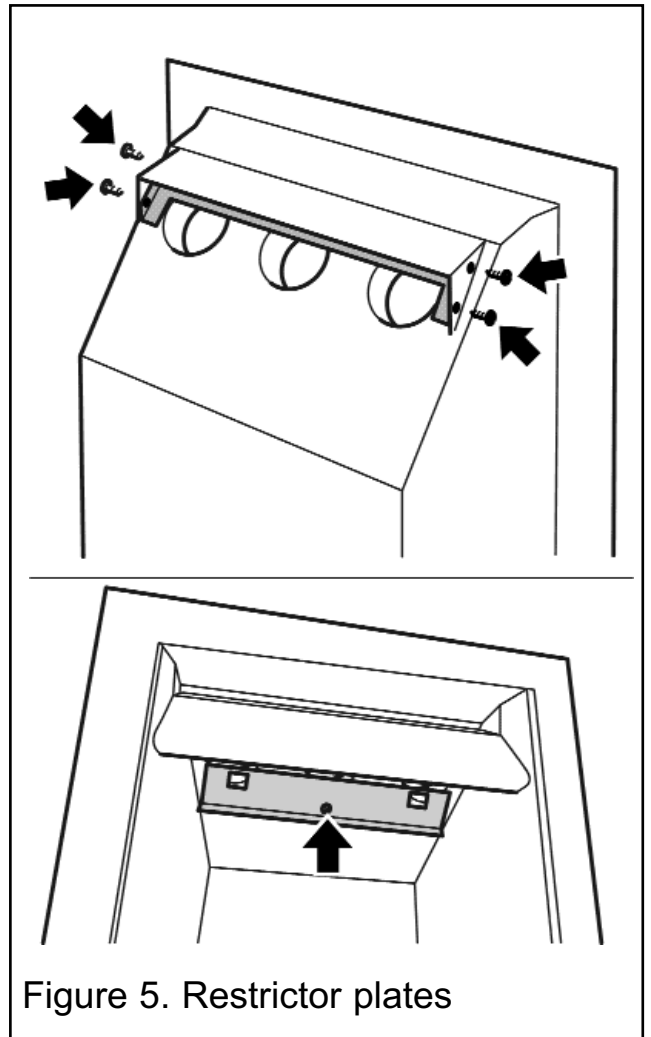

INSTALLER GUIDE

4. Three strips of self adhesive foam sealing material are supplied. Remove the protective backing from the seals and fit them to the rear of the convection box top and side flanges as in figure 6 (On TC models fit the foam seal to the rear of the spacer frame). Ensure that there is no gap between the seals where they meet and that there is full contact with the fireplace front.

The Foam Seal should touch at this point. Ensure that there are no gaps.

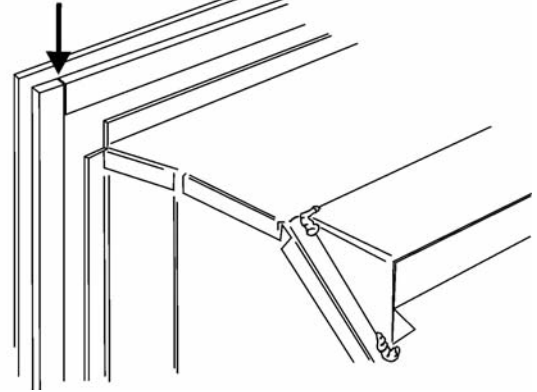

Figure 6. Fitting the foam seal.

6.7 Convection box installation.

1. Drill two holes in the rear wall of the fireplace for the eyebolt plugs. The holes should be drilled in the positions shown in figure 7 using a suitably sized masonry drill for the wall plugs supplied. The holes should be equidistant each side of the centre line of the fireplace to ensure that the appliance finishes centrally in the opening when tension is applied to the cables.

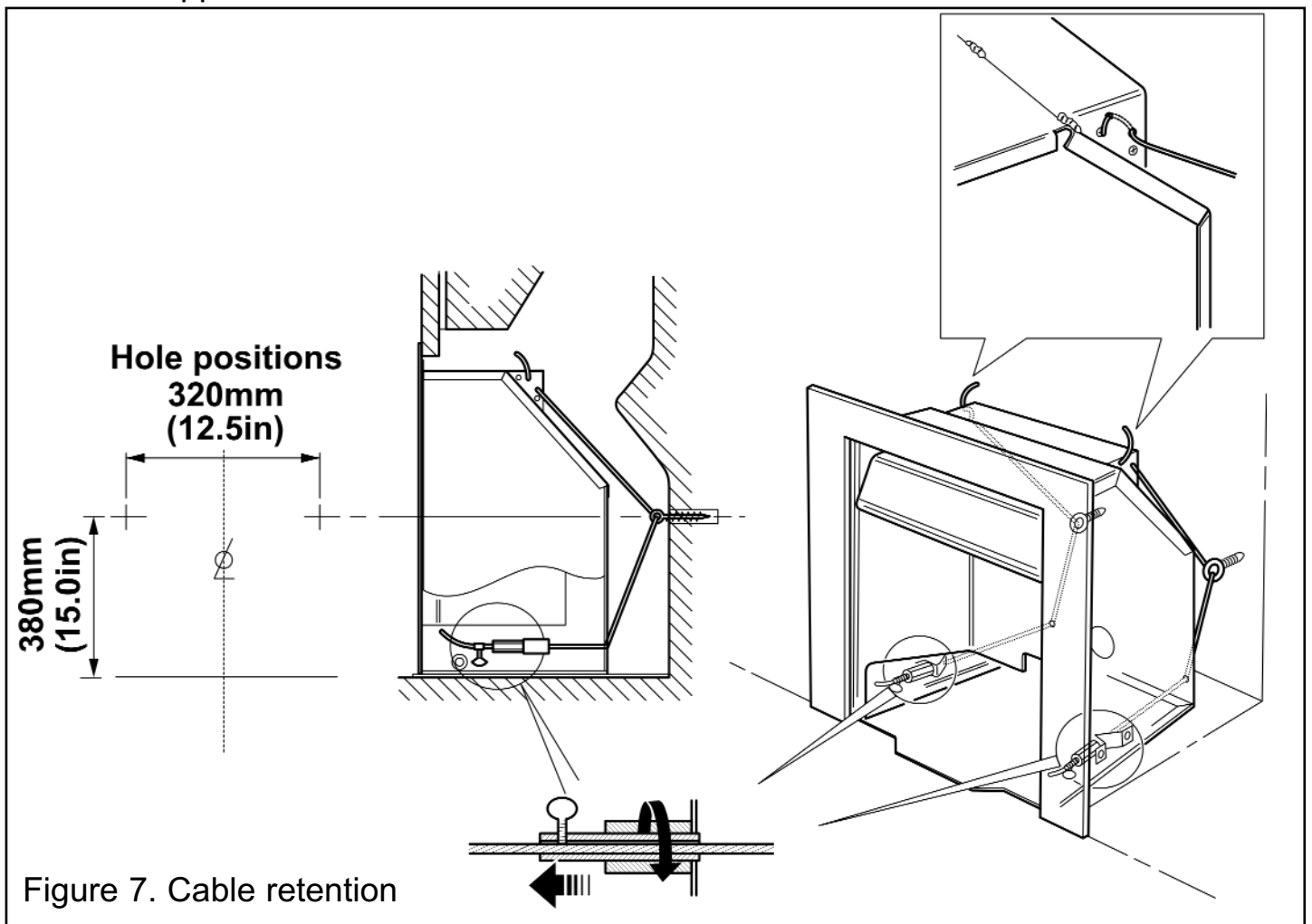

Figure 7. Cable retention

2. Insert a fibre plug into each hole. Use the fibre plugs supplied with this appliance - **Never use plastic plugs instead of the fibre plugs supplied.** Screw the eyebolts

INSTALLER GUIDE

into the plugs. Make sure that the bolts are secure.

3. Place the convection box unit close to the fireplace but allow sufficient access into the fireplace opening so that the cables can be threaded through the eyebolts and returned through the back of the convection box. Insert the convection box into the fireplace feeding the supply pipe through the pierced hole in the rear grommet.

4. The convection box has two holes at each end of the debris deflector (See figure 7). Insert one end of each cable (one cable each side) from the back through the lower of the two holes and return the end through the upper of the holes (See figure 7). Give the cables a pull so that they grip against the debris deflector sides.

5. Thread the cables through the eyebolts. Return the cables through the holes near the bottom of the convection box back panel and through the brackets near the bottom of the convection box sides (See figure 7).

6. Place the convection box fully back into the fireplace opening so that it is sealed against the fireplace front surround.

7. Fit a cable retainer over the bottom end of each cable.

8. Pull each cable taut. Push the cable retainers hard up against the brackets. Tighten the screws in the retainers so that they clamp the cables in position. Apply tension to the cables by turning the hexagonal adjusters by hand (See figure 7).

9. Inspect the installation of the convection box against the fireplace surround. If the convection box is aligned squarely and the sealing is satisfactory, fully tighten the cable retainers.

10. If the convection box is not correctly aligned, release the tension on the cables by slackening the screws and turning the hexagonal adjusters fully anticlockwise. The convection box should then automatically realign itself. Pull each cable taut again and push the cable retainers back against the brackets. Again, tighten the screws in the retainers and apply tension to the cables by turning the hexagonal adjusters clockwise as far as possible.

11. Keep the free length of the inside the convection box so that they are available to allow easy removal and refitting of the appliance during subsequent service calls. Do not cut off the free lengths of cable.

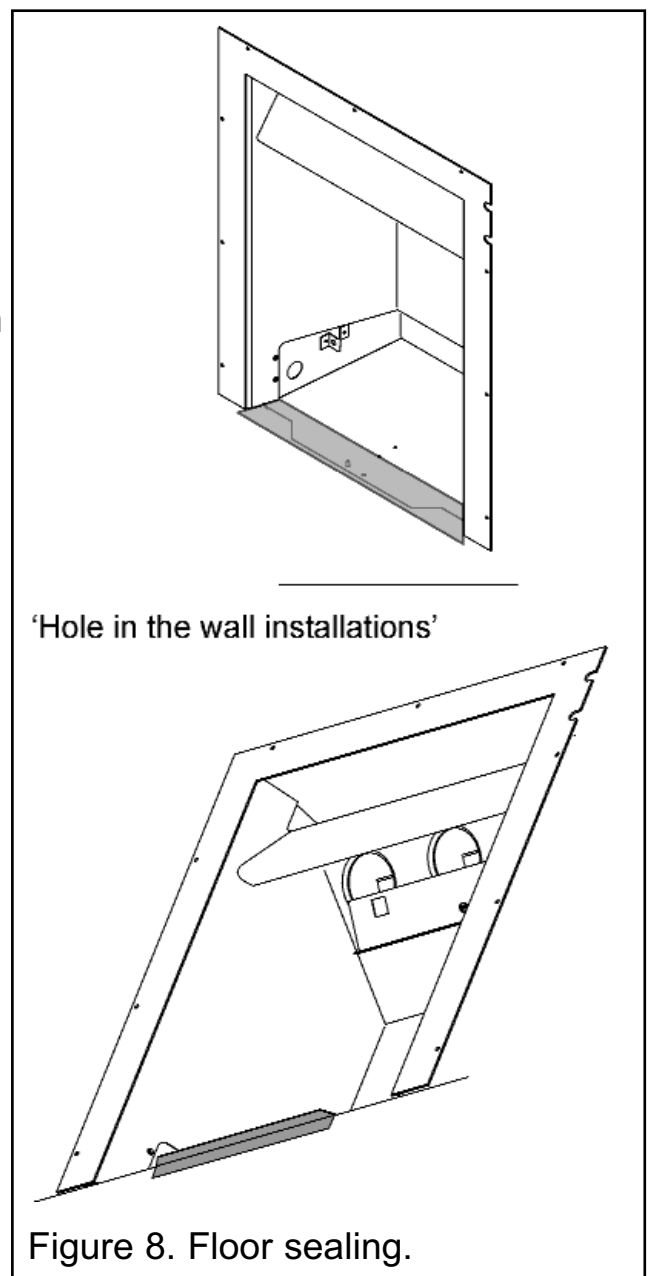

INSTALLER GUIDE

6.8 Sealing floor front - all installations.

Using the floor sealing tape supplied, seal the bottom of the convection box to the base of the fireplace opening (and hearth where applicable) (See figure 8).

Make sure that the whole length of the front edge of the convection box is fully sealed.

On elevated 'hole in the wall' / elevated installations seal the underside of the convection box base (See figure 8).

7. BURNER AND SUPPLY PIPE INSTALLATION

Installing the burner and supply pipe.

The burner is produced from a soft ceramic material and should be handled carefully. There are two sets of burner ports. One set are located on the top face of the burner, and the other, on the front face. Each unit is flame tested before it leaves the factory, and as a result, some slight discolouration may be evident around the burner ports. There may also be some slight surface cracking evident on the burner, which is completely normal and is not detrimental to performance. The burner is retained by two clamps and set in position before it leaves the factory.

1. Check that the injector is aligned straight and central to the venturi. Check that the pilot unit is clear of the front face of the burner by 2-4mm.

2. For installation with a convection box.

Refit the burner unit to the convection box with one nut.

On Top control (TC) models the battery lead and control leads will have to be passed through the grommet on the right hand side of the convection box before fitting the burner. With the burner in place, connect the battery lead to the battery box. Connect the control leads to the appropriate sized tags on the top left of the gas valve. Ensure that these leads do not come into contact with the underside of the burner tray.

2. For installation without a convection box.

Centre the burner tray in the fireplace opening with the tray as far to the rear as possible. Secure the burner in position and fix through the centre front leg into the hearth using a fibre wall plug and fixing screw (supplied).

3. Connect the supply line to the appliance.

4. Turn on the gas supply and pressure check the installation pipework for gas soundness. In the United Kingdom (GB) check in accordance with the current edition of BS 6891. In the Republic of Ireland check in accordance with the current edition of IS 813 "Domestic Gas Installations".

INSTALLER GUIDE

8. FITTING THE CERAMIC FUEL EFFECT

The installer and owner guide for the ceramic fuel effect is supplied with the ceramic fuel effect. It is important that the fitting guide for the ceramic fuel effect be placed inside or attached to this guide and handed to the customer following completion of the 'final review' section.

9. FULL OPERATIONAL CHECKS

9.1 General information.

When operating the fire for the first time, some vapours may be given off which could set off smoke alarms in the vicinity. These vapours are quite normal with new appliances. They are totally harmless and will disappear after a few hours use.

Note: We recommend you use the appliance at a low setting for the first few hours of use to reduce the thermal cracking of the burner surface. Surface cracking of the burner is normal and is no cause for concern. Whilst binding materials are being burnt out of the burner there may be a slight odour.

9.2 Checking the operation of the MANUAL CONTROL burner.

9.2.1 To light the pilot.

1. Ensure that the control knob is turned to the OFF position. Depress the control knob and turn anticlockwise until the IGNITION position is reached, continue turning the knob to activate the piezo ignition. Two 'clicks' will be observed, and the pilot should ignite. Hold the knob in this position (keeping it depressed) for ten seconds to allow the flame supervision device to establish.
2. Observe if it is alight by looking through the slots to the left hand end of the front ceramic fuel effect.
3. If the pilot does not light immediately, repeat the above procedure, keeping the knob depressed for several seconds in order to purge any air from the system.
4. If after ten seconds, ignition has not occurred, turn the control knob back to the OFF position and repeat the ignition procedure after 3 minutes.
5. Once the pilot is lit, keep the control knob depressed for ten seconds to allow the flame supervision device to establish.

When the control knob is released, the pilot should remain lit. If the pilot fails to remain lit, repeat the ignition procedure, this time keeping the control knob depressed for a longer period of time.

9.2.2 Lighting the main burner.

Once the pilot light is established the main burner can be lit by turning the control knob anticlockwise to the HIGH position.

INSTALLER GUIDE

9.2.3 Controlling the heat setting.

In order to change from one setting to another depress the control knob slightly and turn the knob to the required position. Alternatively, if a setting between LOW and HIGH is required, then the control knob may be turned to this position.

9.2.4 To turn the fire back to pilot setting.

Depress the control knob and turn clockwise until the pilot setting is reached. To turn the fire OFF, ensure the control knob is in the pilot position, depress the control knob and turn clockwise to the OFF position.

9.3 Checking the operation of the REMOTE CONTROL (RC) burner.

9.3.1 Fitting batteries to the remote control handset.

The remote control handset is battery powered. There is a 9 Volt 'PP3' size battery supplied. Remove the rear battery compartment cover from the remote control handset. To do this push the tab towards the bottom of the handset and lift (See figure 9). Fit the battery in to the handset. Replace the cover.

9.3.2 Fitting batteries to the receiver box.

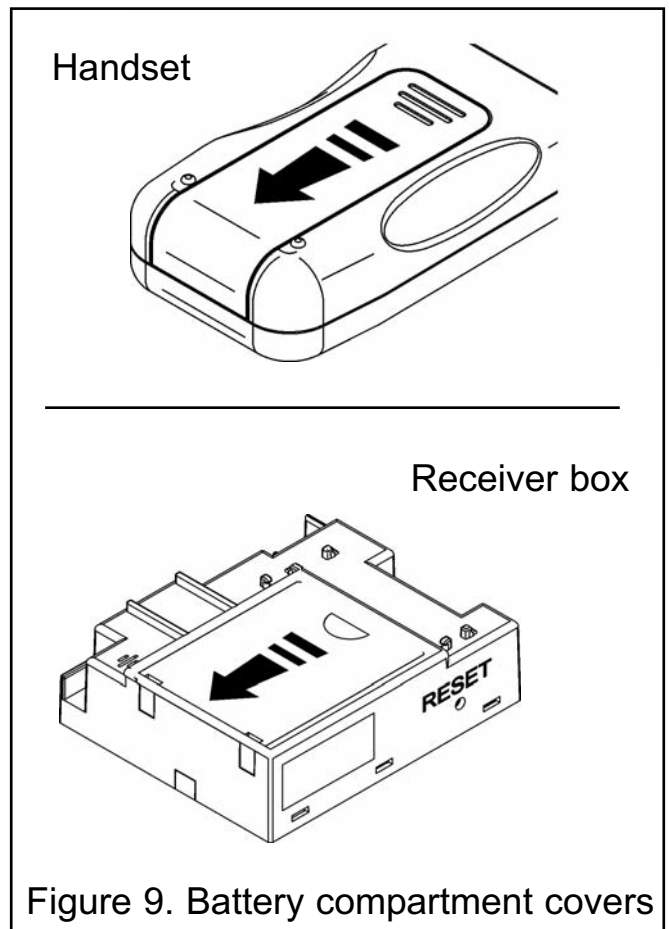

The gas valve and receiver are battery powered. There are four 1.5 Volt 'AA' size batteries supplied. Locate the batteries in the receiver box. To do this slide the receiver box forward and clear of its support. Slide the battery compartment cover clear (See figure 9) and fit the batteries. It is important that the +ve and -ve symbols on the battery match those of the illustration inside the battery holder. Replace the cover and receiver box. **It is important that the wires from the receiver box do not touch the underside of the burner tray.**



INSTALLER GUIDE

9.3.3 Checking the ignition operation.

Place the 'ON/OFF' switch to the '-' (On position). This is on the front of the gas valve (See figure 10).

Simultaneously press and hold the  (star) button and  (up arrow) button. until a short acoustic signal confirms the start sequence has begun; release buttons. Continuing signals confirms the ignition is in progress. There will be a slight delay and several sparks should be seen between the electrode and pilot tip. If there are no sparks check the following: -

Ensure that the electrode lead is connected to the terminal at the base of the electrode.

If the above is correct, check for damage to the electrode lead.

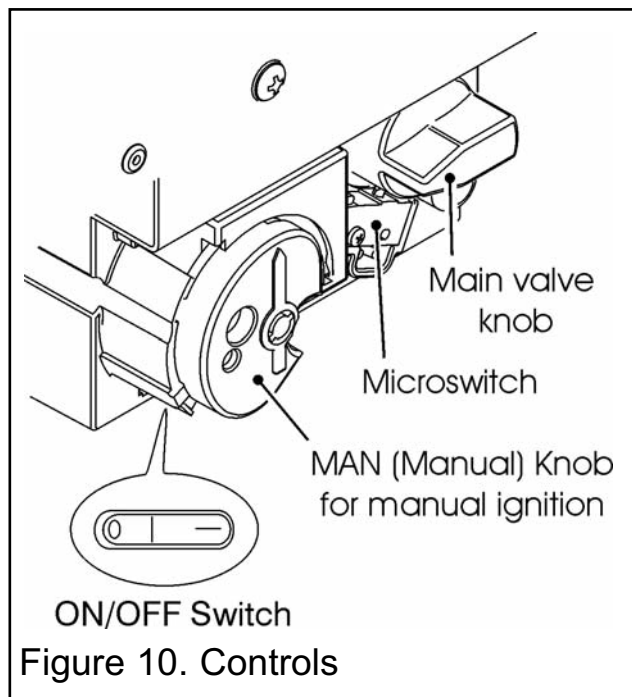

Once pilot ignition is confirmed there is main gas flow.





WARNING

When pilot ignition is confirmed, the motor turns automatically to maximum flame height.

9.3.4 Adjusting flame height.

When the burner is operating press the  (up arrow) button to increase the flame height and press the  (down arrow) to decrease the flame height. For fine adjustment tap the up/down buttons.

9.3.5 Adjusting to pilot only setting.

When the burner is operating press and hold the  (down arrow) until the burner flame extinguishes. To turn the main burner on again simply press and hold the  (up arrow) button.

9.3.6 Turning off.

To turn the fire off press the 'OFF' button.

INSTALLER GUIDE

9.4 Adjusting the remote control handset / receiver code.

If a customer has other devices that interfere with the operation of the fire, or if more than one Airflame remote control is installed in the same room, it will be necessary to adjust the remote control handset / receiver electronic code. To do this complete the following:

Remove the battery compartment cover from the rear of the remote control handset.

There are four DIP switches located above the battery (See figure 11). Change the DIP switch position. Fit the battery compartment cover.

Slide out the receiver box from the right hand side of the burner. Press and hold the receiver's reset button until you hear two (2) acoustic signals. After the second longer signal, release the reset button and within the subsequent twenty (20) seconds, press the ▽ (down arrow) on the remote handset until you hear an additional long acoustic signal confirming the new code is set.

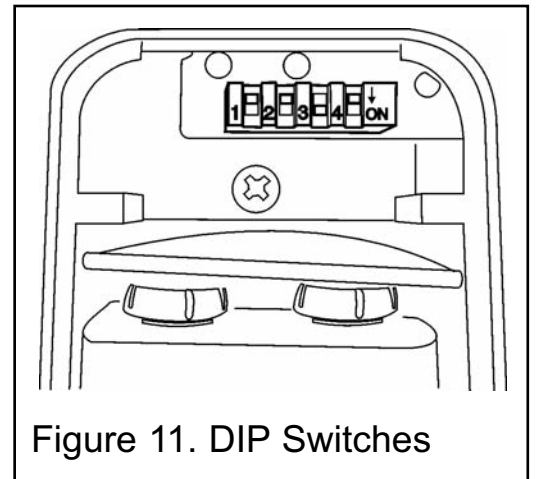

Figure 11. DIP Switches

Battery Life & Replacement

Please note: In order to ensure maximum battery life and optimal performance, we recommend that only 'Long Life' alkaline type replacement batteries are used.

9.5 Checking the operation of the TOP CONTROL (TC) burner.

This fire may be controlled manually, by use of the controls mounted on the appliance. The flame settings may also be controlled by means of the touch button control on the upper right hand side of the fire.

9.5.1 Preliminaries.

1. Remove the elastic band retaining the battery holder.
2. Slide the battery holder out of its retention housing. Remove the retaining screw and discard. Fit the four 'AA' batteries as indicated inside the battery holder.
3. Slide the battery holder back into its housing.
4. Open the isolating valve on the inlet connector.

9.5.2 Lighting the pilot.

Please note:- The fire must be lit manually.

1. Ensure that the pilot burner control knob is in the OFF position (Number 1 in figure 12).
2. Depress the pilot burner control knob and turn anti-clockwise to the ignition position (Number 2 in figure 12) to activate the piezo ignition system. A 'click' will be heard

INSTALLER GUIDE

and the pilot should light. Observe if it is alight by looking through the slots to the left hand end of the front ceramic fuel effect. If the pilot does not light immediately, repeat the above procedure, keeping the knob depressed for several seconds in order to purge any air from the system.

If after ten seconds, ignition has not occurred, turn the control knob back to the OFF position. Wait 30 seconds and then repeat the ignition procedure.

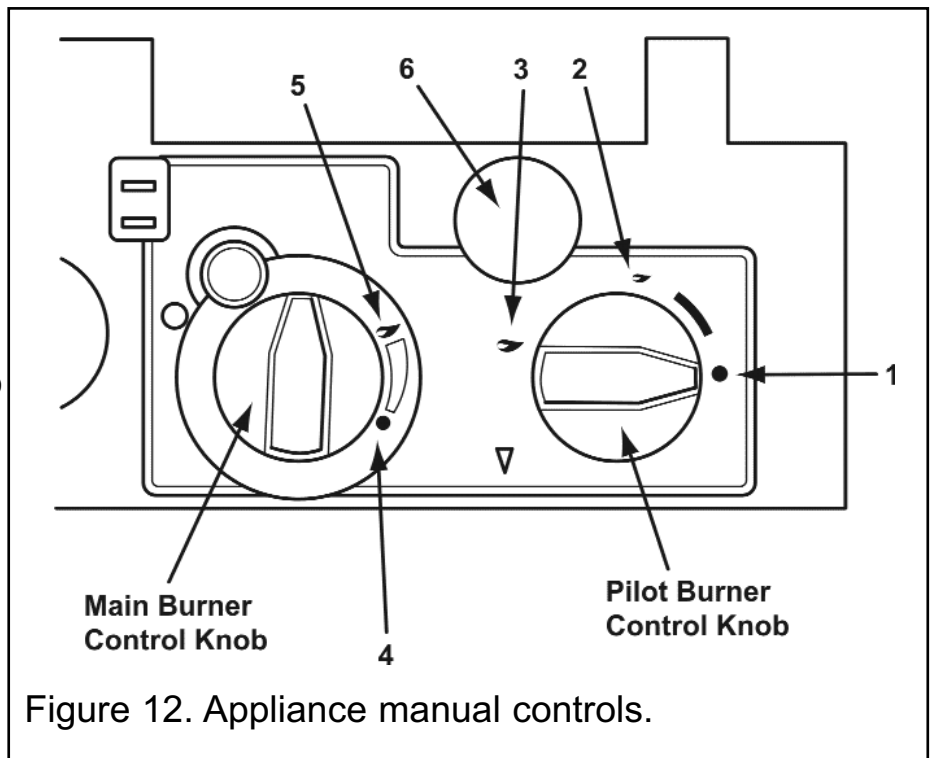

Figure 12. Appliance manual controls.

3. When the pilot is alight keep the knob depressed for ten seconds to allow the pilot flame to stabilise.

4. Release the knob. When the knob is released, the pilot should remain alight. If the pilot fails to remain alight, repeat the ignition procedure, this time keeping the knob depressed for a longer period of time.

9.5.3 Checking the heat settings.

1. Once the pilot light is established, light the main burner by turning the pilot burner control knob anti-clockwise to the "main burner on" position (Number 3 in figure 12), and by then turning the main burner control knob to the high position (Number 5 in figure 12).

2. Check the full range of heat settings by turning the main burner control knob slowly between the high position and the low position (Number 4 in figure 12).

9.5.4 To turn the fire back to pilot setting.

Turn the main burner control knob fully clockwise. Alternatively turn the pilot burner control knob clockwise to the ignition position (Number 2 in figure 12).

9.5.5 To turn the fire off.

Rotate the pilot/burner control knob clockwise to position 1, as shown in figure 12.

9.5.6 Using the Top Control.

1. Keep the pilot burner at the "main burner on" position. Check the full range of main burner heat settings using the Top Control. In order to vary the flame effect between High and Low positions, press, and keep depressed, either the High button, or the Low button as appropriate (See figure 13).

2. Use the Top Control to switch to the pilot only setting by depressing the Low button until only the pilot flame remains alight.

INSTALLER GUIDE

3. Turn the fire off by rotating the pilot burner control knob to the OFF position (Number 1 in figure 12).

Battery Life & Replacement

Please note: In order to ensure maximum battery life and optimal performance, we recommend that only 'Long Life' alkaline type replacement batteries are used.

9.6 Inlet pressure check.

The appliance is pre-set to give the correct heat input at the inlet pressure shown in section 3 of this manual. No adjustment is necessary.

1. Attach a pressure gauge to the pressure test point (See figure 14).

2. If closed, open the isolating valve at the inlet 'T' connector.

3. Follow the lighting procedure (described further on in this manual) to establish the pilot and then turn to maximum setting. Check the gas pressure (See section 3 - Appliance Data).

4. After checking, turn off the appliance. Remove the pressure gauge and replace the test point sealing screw.

5. Relight the appliance. Turn to the maximum output position and test around the sealing screw for gas soundness with a suitable leak detection fluid.

When the above checks have been completed close the isolating valve on the inlet 'T' connector and allow the fire to cool.

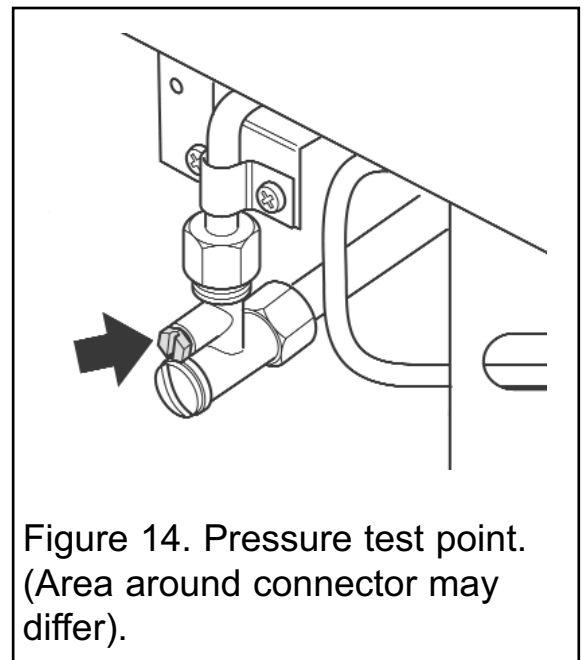
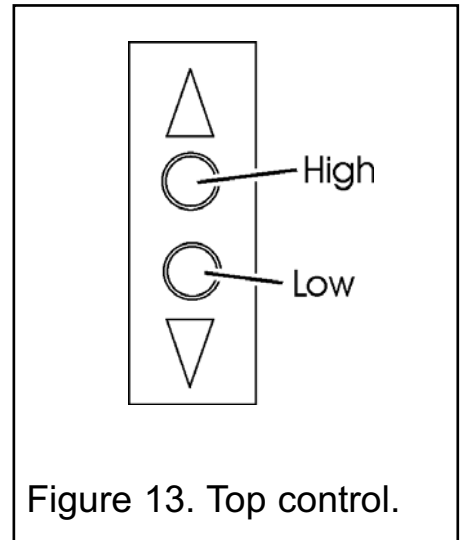

INSTALLER GUIDE

9.7. Aeration setting for fires fitted with aeration control.

To operate the aeration control system, the following procedure should be followed:

1. Allow the appliance to warm up, (for at least fifteen minutes) in the fully aerated position, with the control lever pushed in to the locked position (See figure 15).

2. Switch to the minimum aerated position by slightly lifting the control lever. A spring mechanism will close the aeration shutter.

3. To return to the fully aerated position push the control lever in and slightly downward until it rests in its locked position.

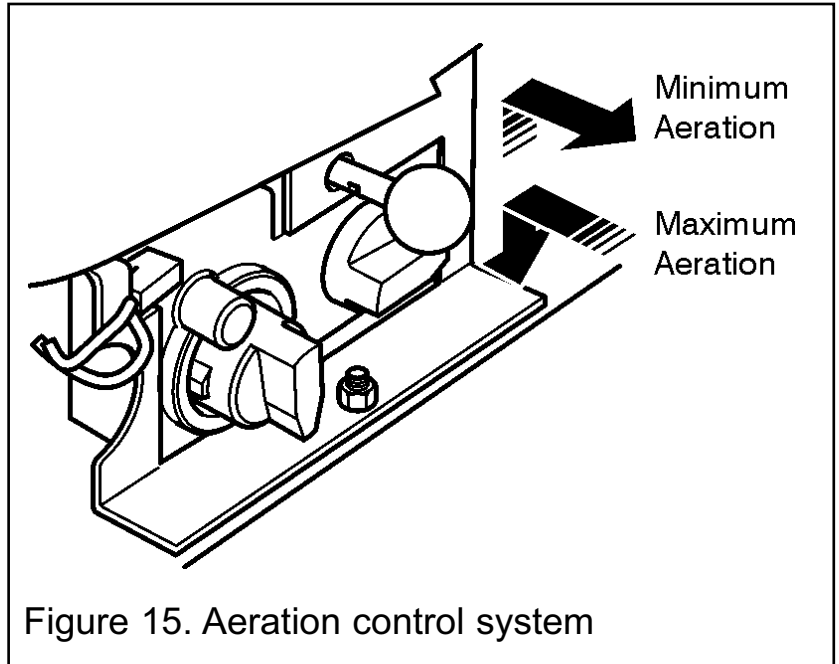

Figure 15. Aeration control system

Inform the customer that it is advisable to run the fire in its fully aerated mode (control knob pushed in) at the beginning of each

operation and if running at the minimum rate setting, or to burn off any carbon deposits which may have built up after prolonged use of the minimum aerated setting. Demonstrate the use of the aeration control to the customer.

10. SPILLAGE AND FLAME SUPERVISION CHECKS

10.1 Spillage check.

A spillage check must be made before leaving the installed appliance with the customer. Make this with the ceramic fuel effect in position.

1. Close all doors and windows in the room containing the appliance.
2. Set the aeration control to the fully aerated position (where fitted).
3. Light the appliance and set at the maximum burning position.
4. Place the bottom fire front casting / firefront and "ash pan" cover in position. (Where applicable - see section 11)
5. Leave the appliance on for ten minutes.
6. The smoke match (inserted in the tube supplied) should be placed in the convection box / fireplace opening 30mm from either end of the convection box opening / fireplace opening as shown in figure 16.

INSTALLER GUIDE

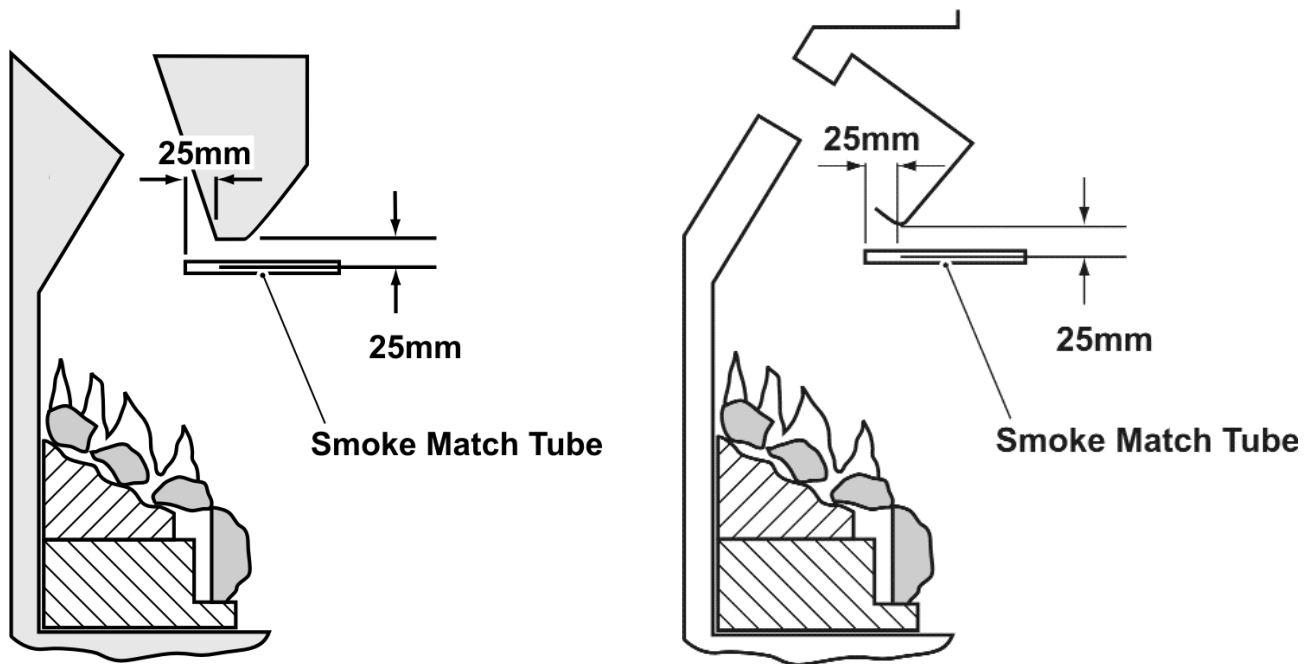

Inset Tray (DGF) installations

Convection box installations

Figure 16. Spillage test.

The installation is satisfactory if smoke is drawn into the convection box opening / fireplace opening.

If smoke is not drawn into the convection box opening / fireplace opening leave the appliance alight at the maximum setting for a further 15 minutes and then repeat the test.

If smoke is still not drawn into the appliance disconnect the appliance and seek expert advice.

Convection box installations

If the smoke is still not drawn into the convection box opening inspect the sealing of the convection box to the fireplace surround.

If the sealing is satisfactory turn the appliance off, allow to cool, remove the internal restrictor plate (See figure 5) and retest. This is not applicable for installations having a flue liner of 125mm since the restrictors should already have been removed (See section 6.2).

If the smoke is still not drawn into the appliance turn the appliance off, allow to cool, remove the appliance from the fireplace, and detach the outer restrictor plate (See figure 5). Reinstall the appliance and retest. This is not applicable for installations having a flue liner of 125mm since the restrictors should already have been removed (See section 6.2).

7. If the above test is satisfactory repeat the spillage check with the aeration control set at the minimum aeration position.

8. If the above tests are satisfactory open all internal connecting doors, hatches etc. in the room. Keep all doors and windows that open to the outside of the window closed. Recheck for spillage as above. If an extractor fan is installed in the same

INSTALLER GUIDE

room as the appliance or a connecting room check that spillage does not occur with the fan operating and all doors and other openings between the fire and the appliance open.

If the smoke is drawn into the appliance continue with the installation. If the test is not satisfactory disconnect the appliance and advise the customer of the cause of failure.

10.2 Flame supervision & spillage monitoring system.

The pilot unit includes a system that will automatically shut off the gas supply if the pilot flame goes out or if there is insufficient oxygen due to spillage or poor ventilation. Check that the system operates properly as follows;

1. Light the appliance. Set to the maximum burning position and leave for one minute.

2. Manual control models.

Turn the control knob to the 'OFF' position. The pilot and main burner will go out.

2. Remote control (RC) and Top control (TC) models.

Set to the low burning position. Isolate the gas supply at the inlet "T" connector. The pilot and main burner will go out.

Note the time when the pilot goes out. Listen for a snap sound at the gas tap. Note the time when the sound is heard. This sound is caused by an electromagnetic valve shutting off the gas supply through the tap. The valve is located in the body of the tap. The valve should operate within 60 seconds of the pilot going out. If the pilot does not operate within this time do not allow the appliance to be used until the fault has been corrected.

This monitoring system must not be adjusted, bypassed or put out of operation.

This monitoring system or any of its parts must only be exchanged using authorised parts.

Remote control (RC) models and Top control (TC) models.

3. Open the isolating valve on the inlet "T" connector. Screw in the end cap and test for leaks.

4. Turn the fire off.

INSTALLER GUIDE

11. DECORATIVE FIREFRONTS

If the appliance is not supplied with a decorative firefront a slotted firefront with a minimum free area as shown in figure 18 must always be used.

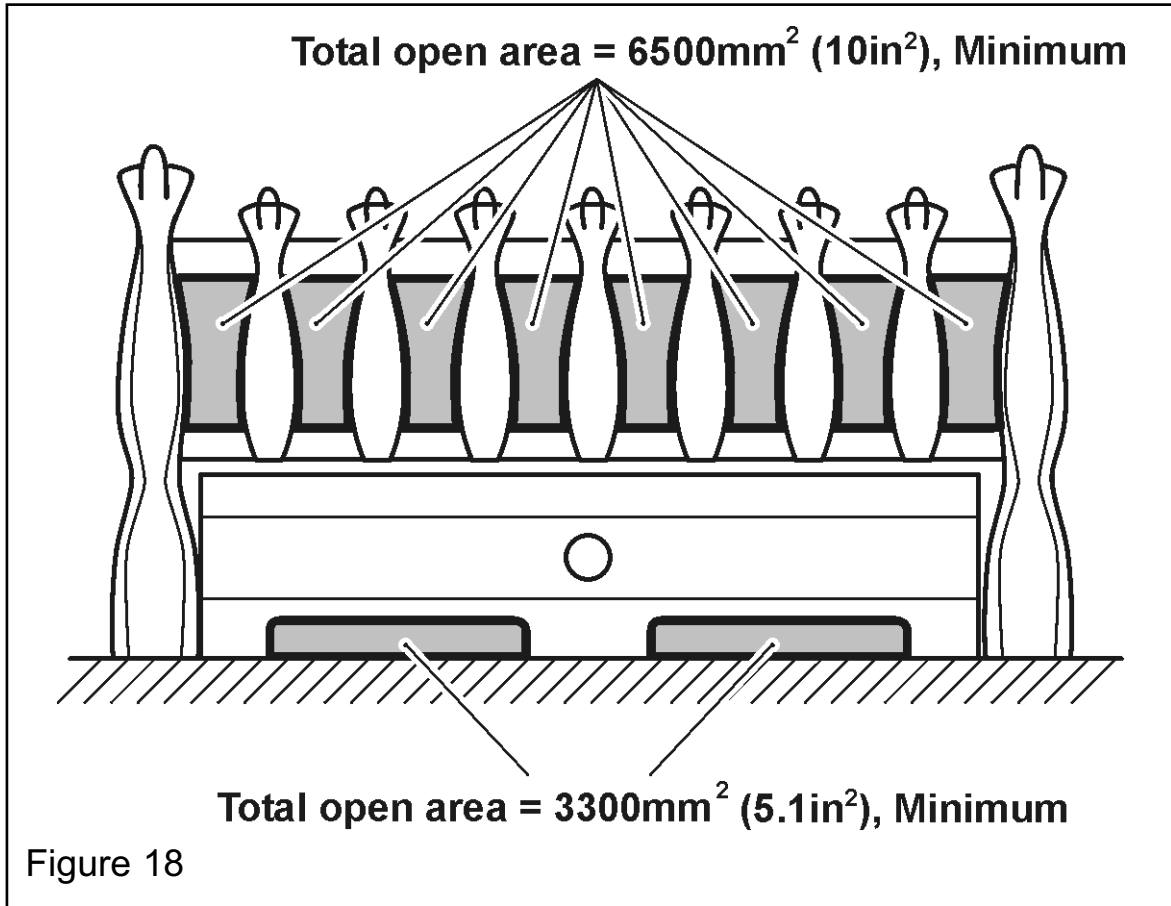

For models supplied with a firefront, the open area may differ slightly from that stated in figure 18. In these cases the firefront will have been tested with the fire and found to be satisfactory for use with the fire.

INSTALLER GUIDE

12. FINAL REVIEW

- 1. COMPLETE THE INFORMATION IN THE WARRANTY AND SERVICE SECTION OF THE OWNER GUIDE (See last pages of the OWNER guide).**
2. Visually inspect the appliance. Clean off any marks incurred during installation.
3. Advise the customer how to operate the appliance. Explain to the customer that the appliance has a flame failure and spillage monitoring system. Point out the explanation of this system shown in the Owner Guide under "Operating your fire". Advise that if the fire goes out for any reason wait at least three minutes before relighting. Stress that if the monitoring system repeatedly shuts off the fire the appliance should be switched off and a specialist should be consulted.
4. Advise the customer that the Owner Guide should be read before operating the fire for the first time.
5. Advise the customer that, when cleaning the appliance, the methods given in the Owner Guide should be followed.
6. Stress that no extra ceramic fuel effect pieces must be added over and above those supplied with the appliance and that any replacements must only be the authorised spares. Warn that ignoring this advice could cause incomplete clearance of the products of combustion with consequent health hazards.
7. Advise the customer that the appliance will operate to its maximum potential if the flue is primed during the first 15-30 minutes of use. To do this simply set the fire to its highest setting. The aeration control (where fitted) should also be set at the maximum aeration position. This will also burn off any carbon deposits that may have formed during previous use.
If using the appliance for long periods it is beneficial to change between settings. This will also help to remove any carbon deposits that may have formed during use.
8. Recommend that the appliance should be serviced by a competent person at least annually.
9. If the appliance is in premises in the United Kingdom occupied by a tenant, point out that, by law, a landlord must have any gas appliance, flue and pipework which is situated in a tenant's premises checked for safety at least every twelve months.
10. Advise that the fire may give off a slight odour while new. This is quite normal and it will disappear after a short period of use.
11. Inform the customer that the serial number for the appliance is located on the information label. The information label is located as in figure 7 of the owner guide.
12. Hand the literature pack with this guide to the customer.

13. SERVICING & PARTS REPLACEMENT

This product uses fuel effect pieces and burner (AC models also include a burner compartment rear wall) containing Refractory Ceramic Fibres (RCF), which are man-made vitreous silicate fibres. Excessive exposure to these materials may cause irritation to eyes, skin and respiratory tract. Consequently, it is important to take care when handling these articles to ensure that the release of dust is kept to a minimum. To ensure that the release of fibres from these RCF articles is kept to a minimum, during installation and servicing we recommend that you use a HEPA filtered vacuum to remove any dust and soot accumulated in and around the fire before and after working on the fire. When replacing these articles we recommend that the replaced items are not broken up, but are sealed within a heavy duty polythene bag, clearly labelled as RCF waste. RCF waste is classed as a stable, non-reactive hazardous waste and may be disposed at a landfill licensed to accept such waste. Protective clothing is not required when handling these articles, but we recommend you follow the normal hygiene rules of not smoking, eating or drinking in the work area and always wash your hands before eating or drinking. This appliance does not contain any component manufactured from asbestos or asbestos related products.

Always turn off the gas supply and allow to cool completely before commencing any servicing (The appliance inlet "T" connector incorporates an isolating valve). Always test for gas soundness and spillage after servicing the appliance.

It is recommended that, at least once a year, the appliance is disconnected and the fireplace opening checked and cleared of any debris.

13.1 Annual maintenance.

The ceramic fuel effect should be removed and any sooting carefully brushed from the surface with a soft brush.

The burner should be removed from the convection box / fireplace opening and any debris carefully removed using a soft brush. Inspect the burner for any damage and repair or replace if necessary. Please note surface cracking of the burner is quite normal.

Check the venturi and injector for linting and clean if necessary.

Clean any debris or carbon from around the pilot unit and check the correct operation of the gas control.

Refit the burner into the convection box / fireplace opening. Reconnect the gas supply and check the soundness of all gas connections.

Refit the ceramic fuel effects as described in the ceramic fuel effect guide. This guide should have been attached to, or placed inside this guide by the installer. Follow the lighting procedure and check for spillage as described in section 11 of this guide. If spillage is found the cause should be identified and remedied.

INSTALLER GUIDE

13.2 To remove the injector.

1. Remove the decorative firefront.
2. Remove the ceramic fuel effect pieces.
3. Shut off the gas supply and disconnect the fire at the inlet "T" connector.
4. Detach the burner unit by removing the fixing nut / screw from the front leg of the burner. On Top Control (TC) models unplug the battery lead from the battery box and the control leads from the top left hand corner of the gas valve.
5. Carefully invert the burner assembly ensuring that the ceramic surfaces are not damaged. Disconnect the injector / supply pipe union.
6. Place the burner assembly upright. Remove the injector.
7. Replace in the reverse order.

13.3 To remove the thermocouple & pilot unit.

1. Remove the decorative firefront.
2. Remove the ceramic fuel effect pieces..
3. Shut off the gas supply and disconnect the fire at the inlet "T" connector.
4. Detach the burner unit by removing the fixing nut / screw from the front leg of the burner.
5. Disconnect the pilot gas feed pipe at the union with the pilot elbow.
6. Disconnect the H.T. lead from the pilot unit.
7. Disconnect the thermocouple from the gas valve.
8. Remove the screw securing the dust cage to the pilot/burner.
9. Carefully remove the dust cage and place aside.
10. Remove the second retaining screw and withdraw the pilot unit.
11. Replace in the reverse order.

Note: The pilot unit is an atmosphere sensing device. It must be replaced as a whole assembly. Its individual components are not separately replaceable.

13.4 To remove the gas valve unit.

1. Remove the decorative firefront.
2. Remove the ceramic fuel effect pieces.
3. Shut off the gas supply and disconnect the fire at the inlet "T" connector.
4. Detach the burner unit by removing the fixing nut / screw from the front leg of the burner.
5. Carefully invert the burner assembly ensuring that the ceramic surfaces are not damaged. Disconnect the inlet pipe union, pilot supply union, manifold pipe union, H.T. lead, and thermocouple connecting nut from the gas valve.

Manual models

6. Remove the control knob by pulling clear of the burner front leg.
7. Unscrew the locknut securing the gas valve to the burner front leg.
8. Replace in the reverse order.

Remote (RC) and Top Control (TC) models.

6. Remove two retaining screws and withdraw the valve from the front leg.
7. Replace in the reverse order.

INSTALLER GUIDE

13.5 To remove the convection box from the fireplace (For models fitted into a convection box).

- 1.** Detach any decorative fascia from the convection box.
- 2.** Remove the bottom decorative firefront.
- 3.** Remove the ceramic ceramic fuel effect pieces.
- 4.** Shut off the gas supply and disconnect the fire at the "T" connector.
- 5.** Detach the burner unit by removing the fixing nut / screw on the burner front leg.
- 6.** Slacken the hexagonal adjusters on the cable retainers and unscrew the thumbscrews to release the cables.
- 7.** Refit the convection box as described in the relevant section of this guide.
- 8.** Refit the rest of the components in the reverse order to their removal.

OWNER GUIDE

FOR WARRANTY AND SERVICE INFORMATION
SEE PAGES 51 TO 55

OWNER GUIDE

LIST OF CONTENTS

<u>Section</u>	<u>Page</u>
SAFETY	40
GAS CONSUMPTION	41
OPERATING THE FIRE	42
The Oxysafe flame sensing & flue blockage safety system.	42
Operating the MANUAL CONTROL burner.	42
Operating the REMOTE CONTROL (RC)burner.	43
Operating the fire WITHOUT the Remote Control Handset.	44
Operating the TOP CONTROL (TC)burner.	45
Setting the aeration on fires fitted with aeration control.	47
CLEANING YOUR FIRE	48
Metal parts.	48
Ceramic burner.	48
Coals, Pebbles and Logs.	48
CERAMIC FUEL EFFECT REFITTING	49
MAINTENANCE	49
Battery Life & Replacement.	49
Regular maintenance.	50
Replacement ceramics.	50
WARRANTY AND SERVICE	51

This gas fire is designed to meet the most stringent quality, performance and safety requirements to provide you with many years' trouble-free service.

This guide aims to improve your understanding and appreciation of your gas fire by providing simple and informative instructions to ensure that you benefit from the excellent performance and features it has to offer.

IF YOU SMELL GAS

- **DON'T SMOKE.**
- **EXTINGUISH ALL NAKED FLAMES.**
- **DON'T TURN ELECTRICAL SWITCHES ON OR OFF.**
- **TURN OFF THE GAS SUPPLY AT THE METER OR TANK AS APPROPRIATE.**
- **OPEN DOORS AND WINDOWS TO GET RID OF THE GAS.**
- **IMMEDIATELY CALL THE GAS EMERGENCY SERVICE FROM A NEIGHBOURS PHONE - SEE YOUR LOCAL TELEPHONE DIRECTORY.**

Do have the fire installed by a competent person. In the United Kingdom, installation must be in accordance with the latest edition of the Gas Safety (installation & use) Regulations. In the Republic of Ireland, installation must be in accordance with all national and local regulations in force.

Do have the chimney swept prior to installation if it was previously used for solid fuel.

Do have the fire installed in accordance with the installation guide.

Do provide a minimum clearance as shown in graph 1 above the base of the fireplace opening to any shelf made of wood or other combustible material.

• *For a shelf up to 150mm deep: Minimum height = 818mm.*

• *For a shelf deeper than 150mm: 818mm + 12.5mm for every 25mm depth over 150mm (See Graph 1).*

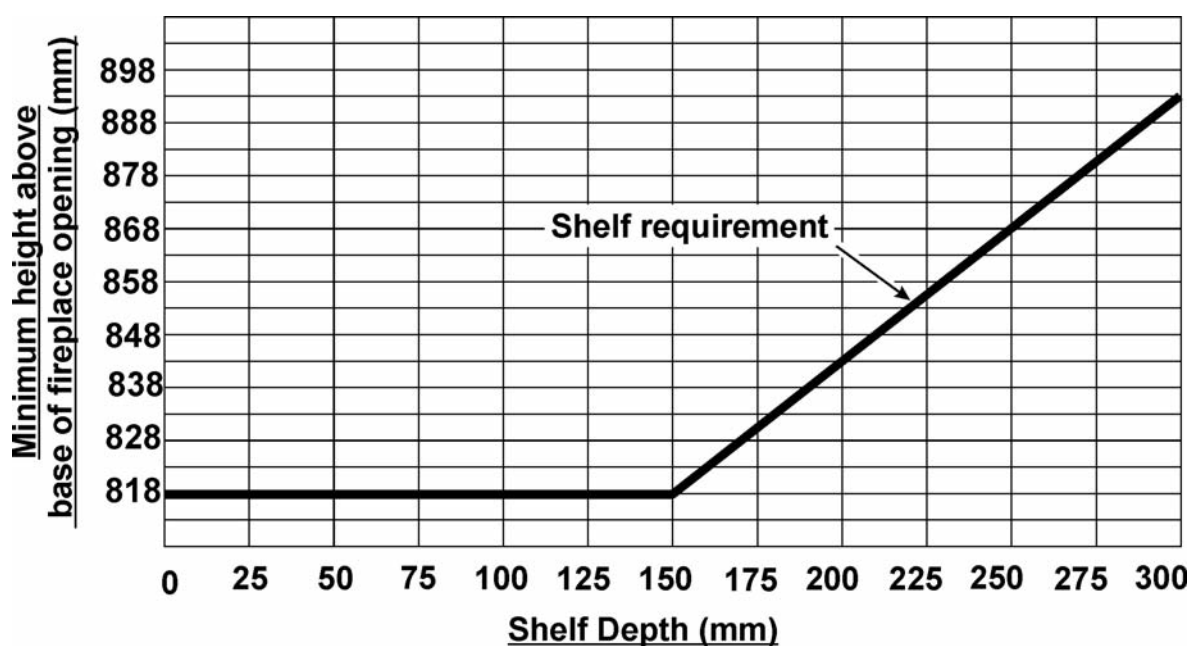

Graph 1. Combustible shelf clearances

Do provide a suitable guard that complies with BS 8423 for the protection of young children, the elderly, the infirm and pet animals. (Although this fire conforms to all the applicable standards, it is a heating appliance and certain parts of its surface will

OWNER GUIDE

become hot).

Do wait three minutes before attempting to relight if the fire is switched off or the flames are extinguished for any reason. (Your fire is fitted with a safety device that will automatically shut off the gas supply to the fire if, for any reason, the flames go out).

Do get advice about the suitability of any wall covering near your fire. Soft wall coverings (e.g. embossed vinyl, etc.) which have a raised pattern are easily affected by heat. They may, therefore, scorch or become discoloured when close to a heating appliance. Please bear this in mind whenever you are considering redecorating.

Don't hang clothing, towels or any other fabrics over the front of the fire.

Don't add any extra fuel effect pieces above the number stated in the guide supplied with the ceramics. This could cause a safety hazard / incorrect combustion. The ceramic guide should have been attached to, or placed inside this guide.

Don't put paper or any other material on the fire.

Don't place any combustible material (rugs, carpet, plastic tiles, etc.) on the hearth.

Don't attempt to clean or service the fire until it has been switched off and allowed to cool completely.

GAS CONSUMPTION

MODEL	HEAT INPUT (kw GROSS)
AF16NV / AF16NV RC / AF16NV 5" LEG	6.95 (Coal or Log)
AC16NV / AC16NV RC AC16NV TC	6.95 (Coal or Log) / 6.3 (Pebble on AC16NV only)
AF18XL / AF18XL RC	10.5
AC18XL / AC18XL RC	10.5
AF16NVP* / AF16NVP RC*	6.2
AC16NVP* / AC16NVP RC*	6.2
AF18XLP* / AF18XLP RC*	10.5
AC18XLP* / AC18XLP RC*	9.0

* When converted to propane using the kits from section 2 of the installer guide.

OWNER GUIDE

OPERATING THE FIRE

PLEASE NOTE

When operating your fire for the first time, some vapours may be given off which may cause a slight odour and could possibly set off any smoke alarms in the immediate vicinity. These vapours are quite normal with new appliances. They are totally harmless and will disappear after a few hours use.

The Oxysafe flame sensing & flue blockage safety system.

For your safety, this appliance is fitted with a flue blockage safety device that will shut down the appliance in the event of abnormal flue conditions. ***This device is NOT a substitute for an independently mounted Carbon Monoxide detector.***

The device will also automatically shut off the gas supply to the fire if the pilot flame goes out due to lack of oxygen or for any other reason.

If this device starts to repeatedly shut off the gas, get expert advice.

This device incorporates a probe that senses that the heat from the pilot flame is correct. If this probe is cool, the device will prevent any gas flow unless the control knob is held in at the ignition position.

If, for any reason, the flames go out when the fire is hot or if the fire is turned off when hot, always ***wait at least three minutes before attempting to relight.***

Note: We recommend you use the appliance at a low setting for the first few hours of use to reduce the thermal cracking of the surface of the burner. Surface cracking of the burner is normal and is no cause for concern.

Operating the MANUAL CONTROL burner.

To light the pilot.

Ensure that the control knob is turned to the OFF position. Depress the control knob and turn anticlockwise until the IGNITION position is reached, continue turning the knob to activate the piezo ignition. Two 'clicks' will be observed, and the pilot should ignite. Hold the knob in this position (keeping it depressed) for ten seconds to allow the flame supervision device to establish.

Observe if it is alight by looking through the slots to the left hand end of the front coals / pebbles / logs.

If the pilot does not light immediately, repeat the above procedure, keeping the knob depressed for several seconds in order to purge any air from the system.

If after ten seconds, ignition has not occurred, turn the control knob back to the OFF position and repeat the ignition procedure after 3 minutes.

OWNER GUIDE

Once the pilot is lit, keep the control knob depressed for ten seconds to allow the flame supervision device to establish.

When the control knob is released, the pilot should remain lit. If the pilot fails to remain lit, repeat the ignition procedure, this time keeping the control knob depressed for a longer period of time.

Lighting the main burner.

Once the pilot light is established the main burner can be lit by turning the control knob anticlockwise to the HIGH position.

Controlling the heat setting.

In order to change from one setting to another depress the control knob slightly and turn the knob to the required position. Alternatively, if a setting between LOW and HIGH is required, then the control knob may be turned to this position.

Note: We recommend you use the appliance at a low setting for the first few hours of use to reduce the thermal cracking of the surface of the burner.

Surface cracking of the burner is normal and is no cause for concern. Whist binding materials are being burnt out of the burner there may be a slight odour.

To turn the fire back to pilot setting.



Depress the control knob and turn clockwise until the pilot setting is reached.

To turn the fire OFF, ensure the control knob is in the pilot position, depress the control knob and turn clockwise to the OFF position.

Operating the REMOTE CONTROL (RC) burner.

Operating the fire WITH the Remote Control Handset.



Lighting the fire.

Simultaneously press and hold the  (star) button and  (up arrow) button until a short acoustic signal confirms the start sequence has begun; release buttons.

Continuing signals confirms the ignition is in progress. There will be a slight delay and several sparks should be seen between the electrode and pilot tip. Once pilot ignition is confirmed there is main gas flow.

When pilot ignition is confirmed, motor turns automatically to maximum flame height.

Adjusting the flame height.

When the burner is operating press the  (up arrow) button to increase the flame height and press the  (down arrow) to decrease the flame height. For fine adjustment tap the up/down buttons.

OWNER GUIDE

Please note:

- The flames on the N.G. appliance will appear predominantly blue. The flames on the L.P.G. appliance will appear predominantly yellow.
- The appliance will operate to its maximum potential if the flue is primed during the first 20 – 30 minutes of operation. To do this, simply set the control knob to its 'HIGH' setting. This will also burn off any dust deposits that may have formed during the appliance being switched off.

Adjusting to the pilot only setting.

When the burner is operating press and hold the ▽ (down arrow) until the burner flame extinguishes. To turn the main burner on again simply press and hold the ▲ (up arrow) button.

To turn off.

To turn the fire off press the 'OFF' button. After turning the fire off the remote control valve will return to its starting position. For this reason it is important to leave the appliance alone for a period of one (1) minute before attempting to relight.

Operating the fire WITHOUT the Remote Control Handset.

Lighting the burner in the event of battery failure.

1. To gain access to the gas valve remote the decorative firefront.
2. The 'main valve knob' is the knob on the right hand side (See figure 1). Turn this knob to the 'OFF', fully clockwise position ↻.
3. The 'manual knob' is the knob on the left hand side (See figure 1). Turn this knob to the 'OFF', fully clockwise ↻ position.
4. Place the 'ON/OFF' switch to the 'O' (Off position).
5. Wait five (5) minutes to clear out any gas. Then smell for gas, including near the floor. If you smell gas STOP! and follow the safety information below.

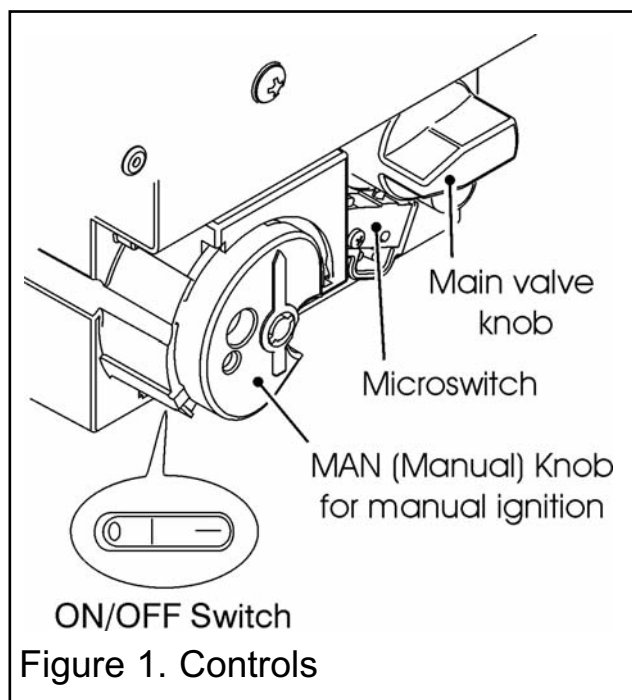

OWNER GUIDE

- DON'T SMOKE.
- EXTINGUISH ALL NAKED FLAMES.
- DON'T TURN ELECTRICAL SWITCHES ON OR OFF.
- TURN OFF THE GAS SUPPLY AT THE METER OR TANK AS APPROPRIATE.
- OPEN DOORS AND WINDOWS TO GET RID OF THE GAS.
- IMMEDIATELY CALL THE GAS EMERGENCY SERVICE FROM A NEIGHBOURS PHONE - SEE YOUR LOCAL TELEPHONE DIRECTORY.

- If you do not smell gas, proceed as below.
6. Place the 'ON/OFF' switch to the '-' (On position).
7. With the 'manual' knob in 'MAN' position a manual pilot valve operator is accessible (See figures 1 & 2).

- Fully push down the manual pilot valve operator using the end of a pencil or similar and hold in, to start pilot gas flow. Immediately light the pilot with a match, while continuing to hold in the manual pilot valve operator for about ten (10) seconds after the pilot is lit. Release manual pilot valve operator. If pilot does not stay lit, repeat steps 2 through 7.

NOTE If the pilot does not stay lit after several tries, turn the gas control knob (main valve knob) to 'OFF' and proceed to step 10.

8. Turn the 'manual' knob to the ON, full counterclockwise  position. The main burner will now light on the max flame setting.

9. Turn main valve knob to the full 'ON' counterclockwise  position.

10. If the appliance will not operate, follow the instructions "To Turn Off" below and call the Wonderfire Technical Helpline **0844 8711 565..**

To turn off.

To turn the fire off press the 'ON/OFF' switch to the 'O' (Off position).

Operating the TOP CONTROL (TC) burner.

This fire may be controlled by use of the controls mounted at the base of the appliance. The flame settings may also be controlled by means of the push button top control.

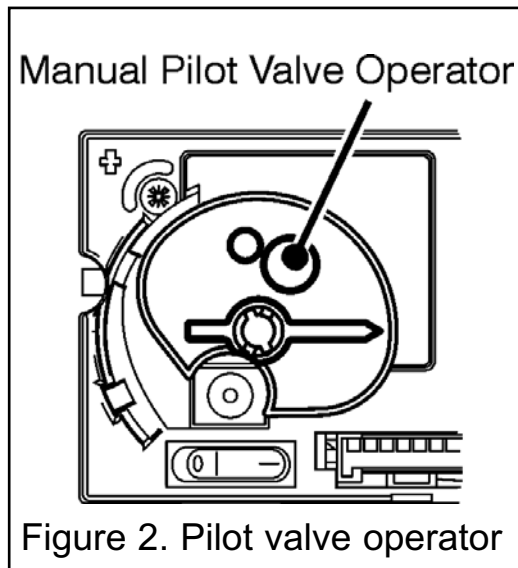

OWNER GUIDE

To light the pilot.

Please note:- The fire must be lit manually.

1. Ensure that the pilot burner control knob is in the OFF position (Number 1 in figure 3).
2. Depress the pilot burner control knob and turn anti-clockwise to the ignition position (Number 2 in figure 3) to activate the piezo ignition system. A 'click' will be heard and the pilot should light. Observe if it is alight by looking through the slots to the left hand end of the front ceramic fuel effect.

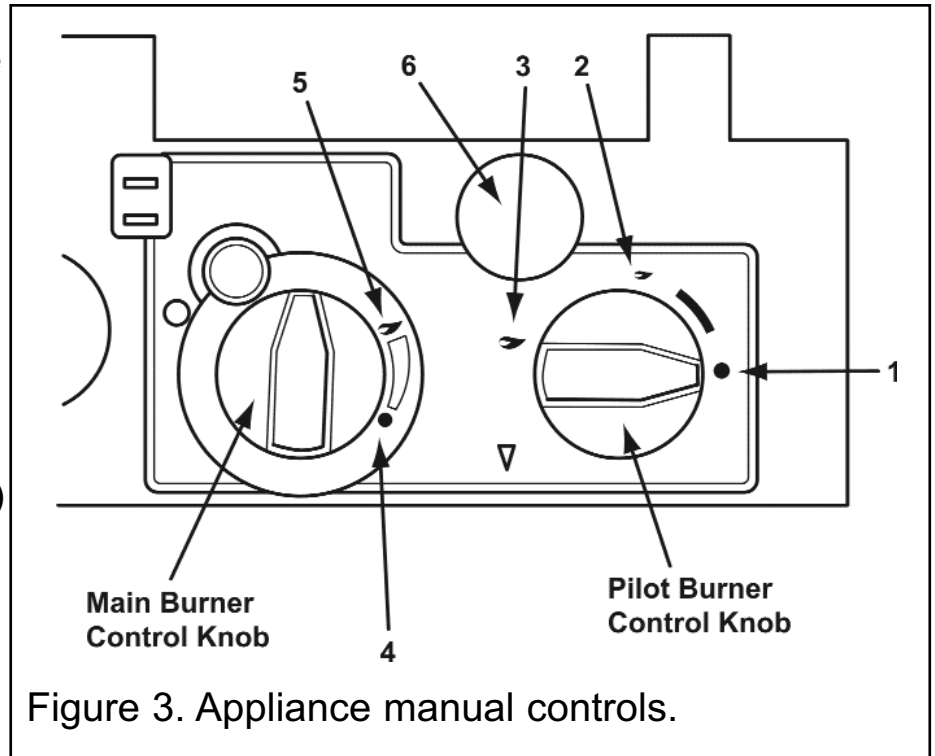

Figure 3. Appliance manual controls.

If the pilot does not light immediately, repeat the above procedure, keeping the knob depressed for several seconds in order to purge any air from the system.

If after ten seconds, ignition has not occurred, turn the control knob back to the OFF position. Wait 30 seconds and then repeat the ignition procedure.

3. When the pilot is alight keep the knob depressed for ten seconds to allow the pilot flame to stabilise.

4. Release the knob. When the knob is released, the pilot should remain alight. If the pilot fails to remain alight, repeat the ignition procedure, this time keeping the knob depressed for a longer period of time.

Controlling the heat setting.

1. Once the pilot light is established, light the main burner by turning the pilot burner control knob anti-clockwise to the "main burner on" position (Number 3 in figure 3), and by then turning the main burner control knob to the high position (Number 5 in figure 3).
2. Check the full range of heat settings by turning the main burner control knob slowly between the high position and the low position (Number 4 in figure 3).

To turn the fire back to pilot setting.

Turn the main burner control knob fully clockwise. Alternatively turn the pilot burner control knob clockwise to the ignition position (Number 2 in figure 3).

To turn the fire off.

Rotate the pilot/burner control knob clockwise to position 1, as shown in figure 3.

OWNER GUIDE

Using the Top Control.

1. Keep the pilot burner at the "main burner on" position. Check the full range of main burner heat settings using the Top Control. In order to vary the flame effect between High and Low positions, press, and keep depressed, either the High button, or the Low button as appropriate (See figure 4).
2. Use the Top Control to switch to the pilot only setting by depressing the Low button until only the pilot flame remains alight.
3. Turn the fire off by rotating the pilot burner control knob to the OFF position (Number 1 in figure 3).

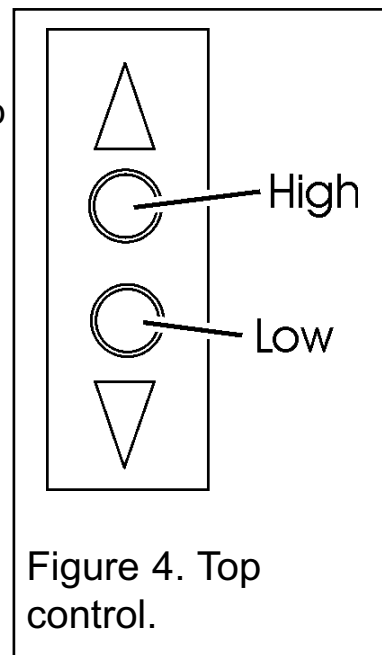

Battery Life & Replacement

Please note: In order to ensure maximum battery life and optimal performance, we recommend that only 'Long Life' alkaline type replacement batteries are used.

Setting the aeration on fires fitted with aeration control.

To operate the aeration control system, the following procedure should be followed:

This appliance is fitted with an aeration control (See figure 5). To operate the aeration control system, the following procedure should be followed:

1. Allow the appliance to warm up, (for at least fifteen minutes) in the fully aerated position, with the aeration control lever pushed in to the locked position (See figure 5, & number 6 in figure 3).
2. To switch to the minimum aerated position slightly lift the control lever. A spring mechanism will close the aeration shutter.
3. Please note : It is advisable to run the fire in its fully aerated mode (control knob pushed in) at the beginning of each operation and if running at the minimum rate setting, or to burn off any carbon deposits which may have built up after prolonged use of the minimum aerated setting.

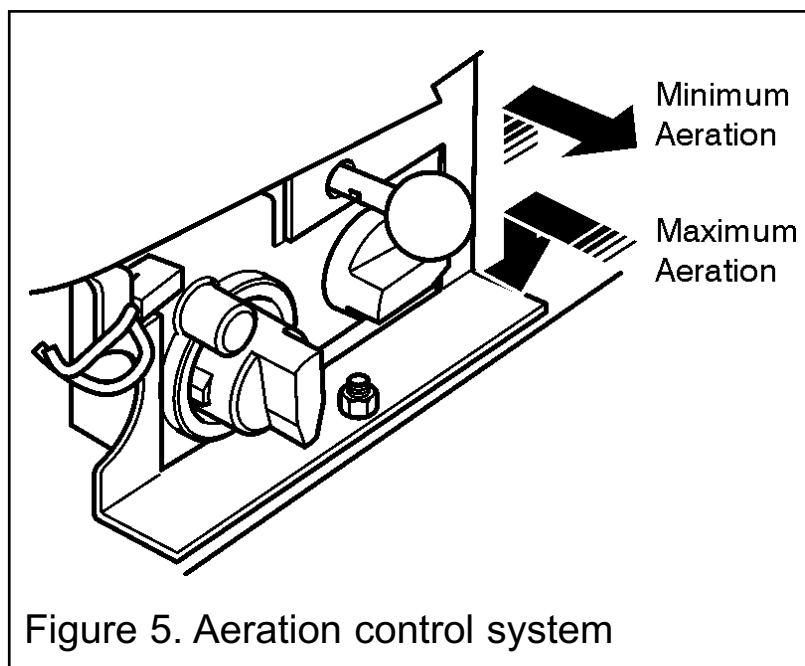

OWNER GUIDE

CLEANING YOUR FIRE

Turn the fire off and allow it to cool completely before attempting any cleaning. Note that the fire will retain heat for some time after it has been turned off.

Metal parts.

Clean the metal parts with a slightly damp cloth and then dry. ***Do not use abrasive cleaners, they could scratch the surface.***

Fascia - Clean the metal parts with a slightly damp cloth and then dry. Some metal finishes may show the marks left by fingerprints etc. If these are If cleaning the metal parts with a slightly damp cloth does not work, apply a very small amount of 'baby oil' to a lint free, non-abrasive cloth and wipe over the surface. Use a clean non-abrasive cloth to wipe off the oil.

Coals, Pebbles and Logs.

This product uses fuel effect pieces containing Refractory Ceramic Fibres (RCF), which are man-made vitreous silicate fibres. Excessive exposure to this material may cause irritation to eyes, skin and respiratory tract. Consequently, it is important to take care when handling these articles to ensure that the release of dust is kept to a minimum.

Light coatings of soot will usually be burnt off during the normal operation of the fire. Should any soot accumulation become excessive, the fuel effect pieces should be removed from the fire for cleaning.

Cleaning should be carried out in a well-ventilated area or in the open air by gently brushing with the pieces held away from your face so that you avoid inhaling the dust. We do not recommend the use of a normal domestic vacuum cleaner that may blow dust back into the air.

We suggest that you remove the ceramic fuel effect in the reverse order to that shown in the fuel bed installer and owner guide.

Ceramic burner.

Remove any deposits of soot or other foreign matter from the solid areas of the burner with a dry soft brush. Be careful not to brush any particles into the open slots. Remove any particles from the slots with a vacuum cleaner fitted with a soft brush attachment. **Do not poke wire, etc. into the slots in the burner.**

OWNER GUIDE

CERAMIC FUEL EFFECT REFITTING

The installer and owner guide for the ceramic fuel effect is separate from this guide. The installer may have attached it to this guide or placed it inside. It is important that the installer and owner guide for the ceramic fuel effect is followed correctly. If replacing the ceramic fuel effect, where a new guide is supplied, follow the installer and owner guide supplied with the replacement fuel effect. Keep the replacement installer and owner guide with this owner guide for future reference.

MAINTENANCE

Battery Life & Replacement.

Please note: In order to ensure maximum battery life and optimal performance, we recommend that only 'Long Life' alkaline type replacement batteries are used.

Changing the batteries in the remote control receiver.

Please note: In order to ensure maximum battery life and optimal performance, we recommend that only 'Long Life' alkaline type replacement batteries are used.

1. Remove the lower firefront / firefront casting.
2. Slide the remote control receiver out of its retention housing.
3. Remove the receiver top cover (See figure 6)
4. Remove and discard the batteries from the receiver.
5. Fit four new 'AA' batteries as indicated inside the receiver base.
6. Replace the receiver top cover. Slide the receiver back into its housing.

Changing the batteries in the top control battery holder.

Please note: In order to ensure maximum battery life and optimal performance, we recommend that only 'Long Life' alkaline type replacement batteries are used.

1. Remove the lower firefront / firefront casting.
2. Slide the battery holder out of its retention housing (See figure 6).
3. Remove and discard the batteries from the holder.
4. Fit four new 'AA' batteries as indicated inside the holder body.
5. Slide the battery holder back into its housing.

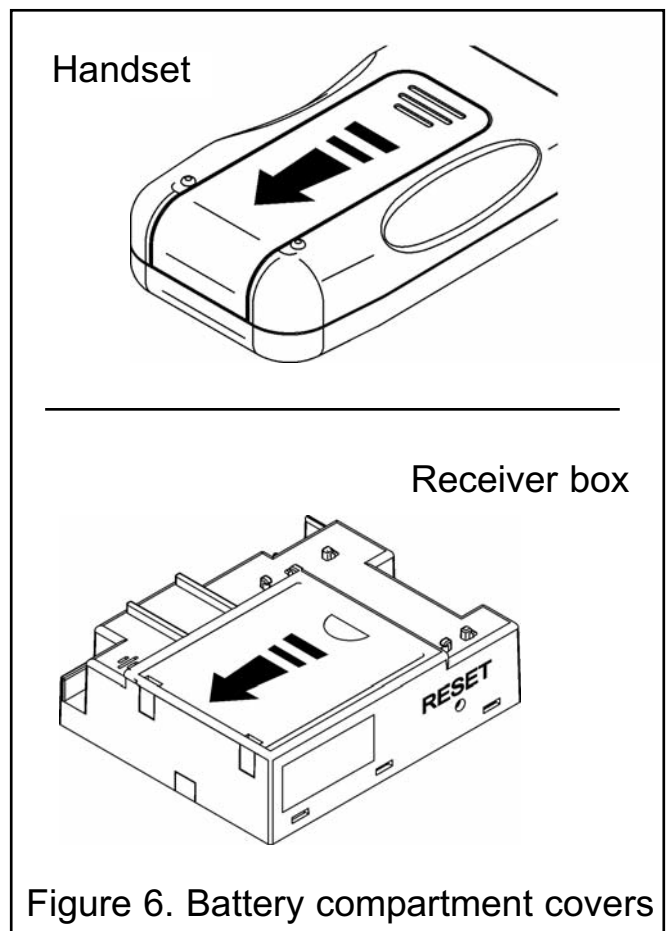

OWNER GUIDE

Changing the battery in the remote control handset.

Please note: In order to ensure maximum battery life and optimal performance, we recommend that only 'Long Life' alkaline type replacement batteries are used.

1. Remove the rear cover from the handset.
2. Remove and discard the batteries from the handset.
3. Fit a new PP3 battery as indicated inside to in the remote control handset.
4. Replace the rear cover on the rear of the handset.

Regular maintenance.

In order to achieve and maintain high levels of personal safety and performance efficiency, it is essential that the opening at the back of the fire (where fitted with a convection box) and the flue are kept clear of any form of obstruction. It is possible that deposits of mortar or soot could fall and accumulate causing the flue to be blocked or restricted and so preventing proper clearance of dangerous exhaust fumes.

In the United Kingdom it is the law that a landlord must have any gas appliance, flue and pipework which is situated in a tenant's premises checked for safety at least every twelve months by a competent person (In the U.K, a CORGI registered installer).

We recommend that all gas appliances and their flues, wherever situated, are checked annually.

Replacement ceramics.

If you wish to replace any of the ceramic fuel effect pieces, spare parts are available nationwide via the '**interpart** stockist network'. For your local stockist consult Yellow pages under Central Heating.

Standard Warranty Terms & Conditions

The warranty is for 12 months subject to contract.

In the United Kingdom servicing can be carried out either by a **heateam** service engineer or a **CORGI** registered installer.

You must register your fire with **heateam**, the service division of Baxi Heating UK Limited, either by completing and returning the registration card or calling our free telephone registration line on **0800 032 72 44**.

It is also a requirement of the warranty that the fire has an annual service (every 12 months) in accordance with the installation and servicing instructions, performed by a CORGI registered engineer. If you would like **heateam** to carry this out this service, please call on **08700 60 30 60**.

Our promise to you

If you experience a fault with your new fire, we aim to provide a safe and high quality repair service supported by our dedicated national network of highly skilled engineers. If your installer can't resolve the problem for you, we will do everything we can to get an engineer out to you as quickly as possible. Nothing in this warranty will affect your statutory rights.

What you need to do if you experience a problem with the operation of the fire:

- You should always contact your installer first, because the cause of the fault may not be related to the fire.
- If your installer confirms that the fault is with the fire and they can't repair it, our friendly customer service team is on hand to help.
- Simply call our service division **heateam** on 08706 090 081 to book an engineer visit or for any general advice that you may need. Our contact centre is open Monday to Friday 8am – 6pm, weekends and Bank Holidays 8.30am – 2pm, excluding Christmas Day and New Years day.

OWNER GUIDE

When calling **heateam**, it would be helpful if you could have the following information to hand:-

1. Fire serial number and fascia code (Located on the information label - See figure 7 on page 55).
2. Date of installation
3. Your installer name and address details
4. Fire make and model number
5. Proof of purchase (if you do not have the fire serial number)

Note: details 1 – 4 should be recorded on pages 54 & 55 at the end of this guide.

What this warranty covers

Free of charge repair or replacement of components found to be of faulty manufacture.

Free of charge replacement of the complete unit providing the failure is related to a manufacturing fault that cannot be repaired or is uneconomic to repair.

What this warranty does not cover

Repairs to fires which haven't been installed and commissioned properly and as set out in the installation instructions.

Faults caused by inadequate supply of gas or electricity (where applicable).

Reimbursement of any third party repair or replacement costs that we haven't been told about or agreed with you in advance.

Compensation or consequential losses (e.g. loss of earnings, business losses, stress and inconvenience) arising from a production breakdown, including repair delays caused by factors outside our reasonable control.

OWNER GUIDE

OWNER GUIDE

The following pages are to be completed by the installer:

Installer Details (Block Capitals)

Installer Name	
Corgi Registration Number.	
Company Name.	
Company Address	
Company Telephone number	
Company Fax number	

Model Identification

MODEL	PRODUCT CODE	PLEASE TICK
AF 16 NV	9500298 (coal)	
	0505411 (log)	
AC 16 NV	9500296 (coal)	
	0505511 (log)	
	0503611 (pebble)	
AF 18 XL	9500360 (coal)	
AC 18 XL	9500361 (coal)	
AF 16 NV RC	0505601 (coal)	
	0505611 (log)	
AC 16 NV RC	0505701 (coal)	
	0505711 (log)	
AF 18 XL RC	0505301 (coal)	
AC 18 XL RC	0505901 (coal)	
AF 16 NV 5" Leg	9505298 (coal)	
AC 16 NV TC	05036T1 (coal)	
	0505811 (log)	

OWNER GUIDE

Serial number (Can be found on information label - See figure 7)

--	--	--	--	--	--	--	--	--	--	--	--	--	--	--

A LABEL CONTAINING THE SERIAL NUMBER MAY HAVE BEEN PLACED INSIDE THIS BOX.

Fascia name (Block Capitals)

Fascia code - Can be found on information label (Block Capitals)

--	--	--	--	--	--	--	--	--	--	--	--	--	--	--

A LABEL CONTAINING THE FASCIA CODE MAY HAVE BEEN PLACED INSIDE THIS BOX.

Brand

Baxi

Valor

Wonderfire

Other.....

Date of Installation

D	D	M	M	Y	Y

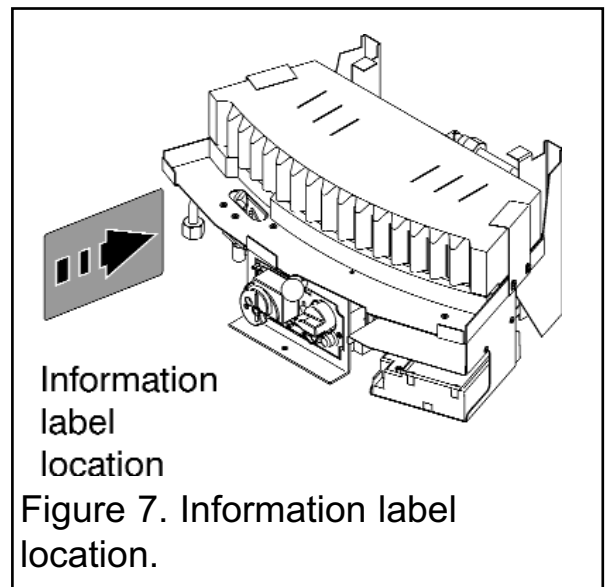

Wonderfire